

MODEL SAS154N-XXXX-XX

Doc No.: OD-SAS154N
(Rev.A/ 2023-08-10)
Sh 1 of 2

(DCN XXXXX)

THIRD ANGLE PROJECTION

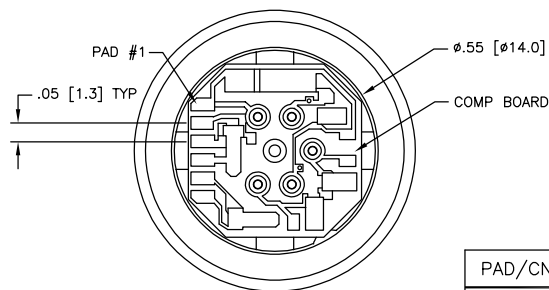
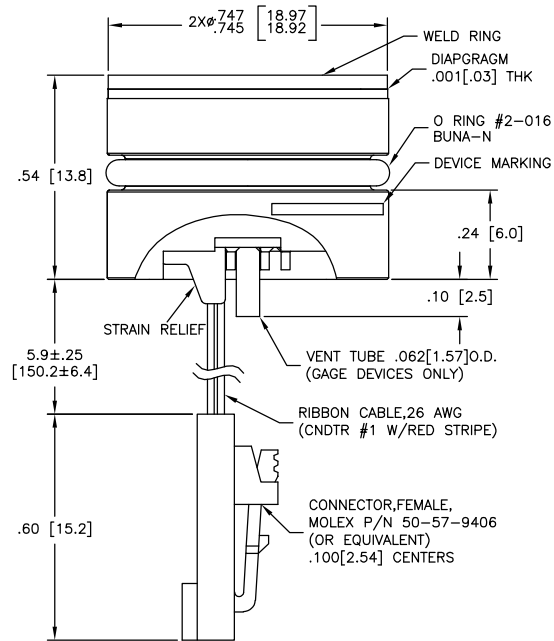
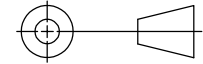

VIEW SHOWN W/O CABLE AND CONNECTOR FOR CLARITY

DIMENSIONS ARE IN INCHES
TOLERANCES (UNLESS SPECIFIED)
XX=.01
XXX=.005
ANGLES=1/2°

PAD/CNDTR	FUNCTION
1	+OUT
2	-EX
3	+EX
4	-OUT
5	GAIN
6	

UNLESS OTHERWISE SPECIFIED:
ALL PARAMETERS ARE MEASURED AT 1.5mA AND AT 25°C

PARAMETERS	005 PSI			≥015PSI			UNITS	NOTES
	MIN	TYP	MAX	MIN	TYP	MAX		
SPAN	50	100	150	75	100	150	mV	1
ZERO PRESSURE OUTPUT	-2.0	0	+2.0	-1.0	0	+1.0	mV	2
PRESSURE NON-LINEARITY	1PSI:±0.30; 5PSI: ±0.20			-0.10	-	+0.10	% SPAN	3
PRESSURE HYSTERESIS	-0.10	±0.02	+0.10	-0.05	±0.02	+0.05	% SPAN	
REPEATABILITY	-	±0.02	-	-	±0.02	-	% SPAN	
INPUT RESISTANCE	2.0K	3.5K	6.5K	2.0K	3.5K	5.8K	Ω	
OUTPUT RESISTANCE	4.0K	-	7.0K	4.0K	-	6.0K	Ω	
TEMPERATURE ERROR, SPAN	-1.0	-	+1.0	-0.75	-	+0.75	% SPAN	4
TEMPERATURE ERROR, OFFSET	1PSI:±1.5; 5PSI: ±1.0			15PSI:±0.75; >15PSI: ±0.5			% SPAN	4
THERMAL HYSTERESIS, SPAN	-0.25	±0.05	+0.25	-0.25	±0.05	+0.25	% SPAN	4
THERMAL HYSTERESIS, OFFSET	-0.25	±0.05	+0.25	-0.25	±0.05	+0.25	% SPAN	4
LONG TERM STABILITY, SPAN	-	±0.10	-	-	±0.10	-	% SPAN/YR	
LONG TERM STABILITY, OFFSET	-	±0.25	-	-	±0.10	-	% SPAN/YR	
SUPPLY CURRENT	0.5	1.5	2.0	0.5	1.5	2.0	mA	5
OUTPUT LOAD RESISTANCE	5M	-	-	5M	-	-	Ω	6
INSULATION RESISTANCE (50 VDC)	50M	-	-	50M	-	-	Ω	7
OUTPUT NOISE (10Hz to 1kHz)	-	1.0	-	-	1.0	-	µV p-p	
RISE TIME (10% to 90%)	-	-	0.1	-	-	0.1	mS	
PROOF PRESSURE	1PSI:10X MAX; 5PSI: 3MAX			-	-	3X	RATED	
BURST PRESSURE	1PSI:12X MAX; 5PSI: 4MAX			-	-	4X	RATED	8
COMPENSATED TEMPERATURE	1PSI: 0 TO 50; 5PSI: 0 TO 70			-20	-	+85	°C	
OPERATING TEMPERATURE	-20	-	+70	-40	-	+125	°C	9
STORAGE TEMPERATURE	-50	-	+125	-50	-	+125	°C	9
MEDIA, PRESSURE PORT	LIQUIDS AND GASES COMPATIBLE WITH 316/316L ST STL							

ORDERING INFORMATION

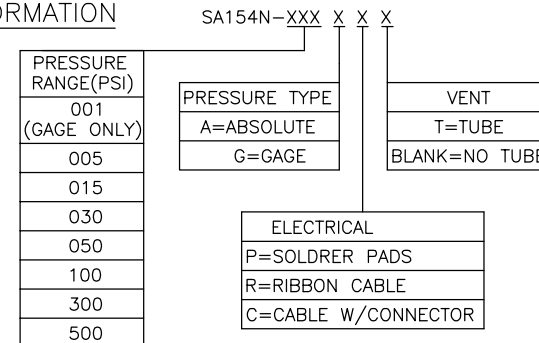

THIRD ANGLE PROJECTION

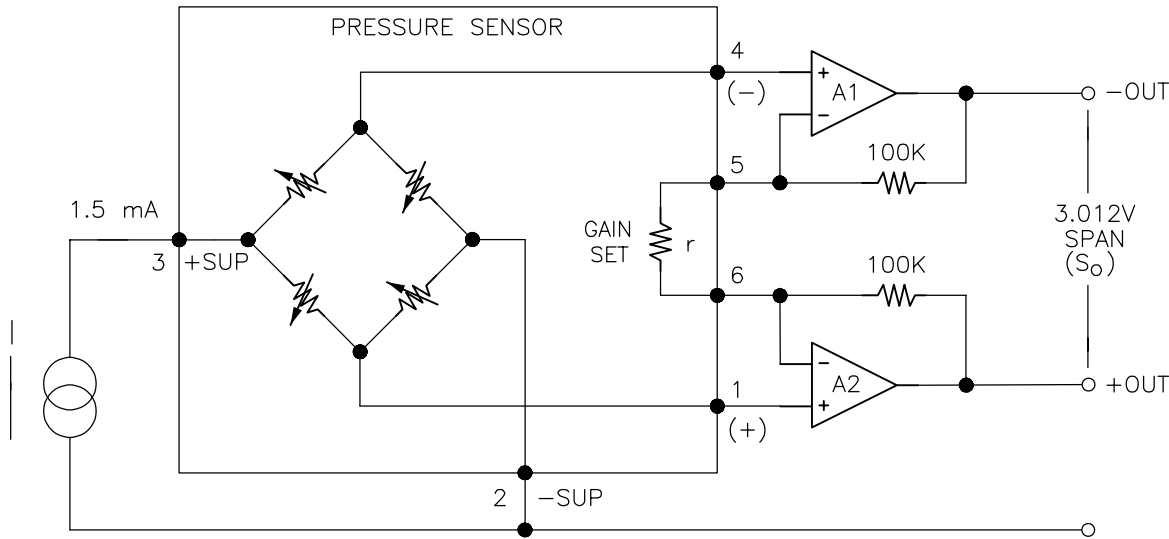
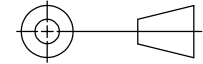

APPLICATION SCHEMATIC

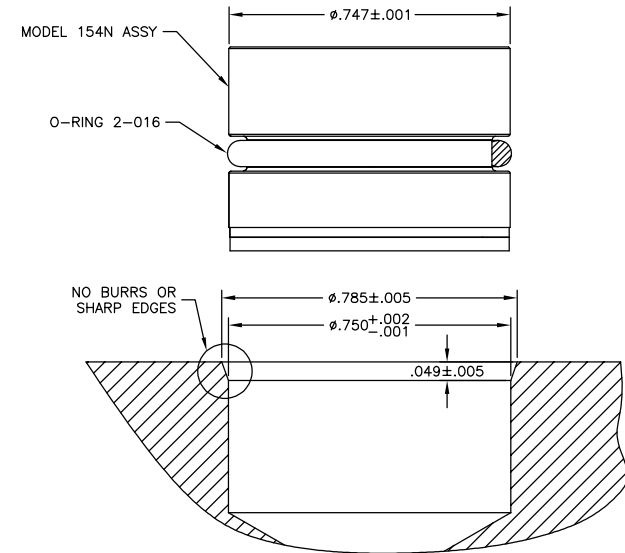

RECOMMENDED MOUNTING DIMENSIONS

Notes

1. For amplified output circuits, 3.012V \pm 1% interchangeability with gain set resistor. See application schematic.
2. Measured at vacuum for absolute (A), ambient for gage (G).
3. Best fit straight line.
4. Over the compensated temperature range with respect to 25°C.
5. Guarantees output/input ratiometricity.
6. Load resistance to reduce measurement errors due to output loading.
7. Between case and sensing element.
8. The maximum pressure that can be applied to a transducer without rupture of either the sensing element or transducer.
9. Maximum temperature range for product with standard cable and connector is -20°C to +105°C.
10. Standard gage units are not recommended for vacuum applications. For vacuum applications below 1/2 atmosphere, consult factory.
11. Device Marking:
Each part shall be identified with Model Number, Pressure Range, Type, Lot Number, Serial Number and Date Code.
12. Shipping/Packaging requirements:
The stainless steel diaphragm is protected by a plastic CAP. Each unit will be packaged individually in a plastic vial with anti-static foam.
13. Direct mechanical Contact with diaphragm is prohibited. Diaphragm surface must remain free of defects (scratches, punctures, dents, fingerprints, etc) for device to operate properly. Caution is advised when handling parts with exposed diaphragms. Use protective cap whenever devices are not in use.