

## SAS58

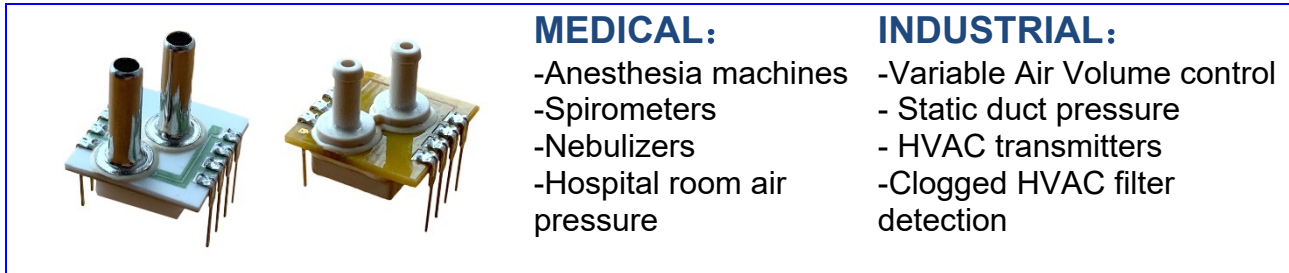

### DESCRIPTION

SAS58 High Accuracy Silicon Ceramic sensor is a piezoresistive silicon pressure sensor, offering an analog/digital output for reading pressure over the specified full-scale pressure span and temperature range. SAS58 Series is fully calibrated and temperature compensated for sensor offset, sensitivity, temperature effects, and non-linearity using an on-board Application Specific Integrated Circuit (ASIC). Calibrated output values for pressure are updated at approximately 1 kHz.

SAS58 Series is calibrated over the temperature range of -10 °C to 60 °C. The sensor is characterized for operation from a single power supply of either 3.3 Vdc or 5.0 Vdc. These sensors measure differential and gage pressures. Differential versions allow application of pressure to either side of the sensing diaphragm. Gage versions are referenced to atmospheric pressure and provide an output proportional to pressure variations from atmosphere. SAS58 Series sensors are intended for use with non-corrosive, non-ionic working fluids. They are designed and manufactured according to standards in ISO 9001.

### FEATURES

- Various package: SAS58 series pressure sensor is designed with various package. Basis substrate is optional with ceramic or FR4 PCB. Pressure port is optional with either PPS or tinned copper material.
- Small size: 15mm\*15mm compact package.
- Energy efficient: Extremely low power consumption, Supply voltage is 3.3 or 5Volts
- RoHS compliant.
- Absolute, Differential and Gage pressure type.
- Wide variety of pressure ranges: Low pressure from  $\pm 1$  mbar to  $\pm 75$  mbar, medium pressure from 1psi to 300psi, provide support for many unique applications.
- Customer orientation: Accuracy, Total error band and compensated temperature can be customized.

- Provides the sensor's true accuracy over a compensated range of -10 °C to 60 °C.
- Industry-leading long-term stability: Even after long-term use and thermal extremes, these sensors perform substantially better relative to stability than any other pressure sensor available in the industry today.
- Industry-leading accuracy: Extremely tight accuracy of  $\pm 0.25$  %FSS BFSL (Full Scale Span Best Fit Straight Line)
- Industry-leading Total Error Band (TEB): Stablesens International specifies TEB—the most comprehensive, clear, and meaningful measurement—that provides the sensor's true accuracy over a compensated range of -10 °C to 60 °C.
- I2C- or SPI-compatible 16-bit digital output (min. 12-bit sensor resolution) accelerates performance through reduced conversion requirements and the convenience of direct interface to microprocessors or microcontrollers;
- Digital output types can offer 10%~90% output or 5%~95% output for optional.

### STANDARD PRESSURE RANGE (INH2O,PSI,KPA,MBAR)

2 inH2O	Gauge, Differential	Digital output
5 inH2O	Gauge, Differential	Digital output
10 inH2O	Gauge, Differential	Digital output
20 inH2O	Gauge, Differential	Digital output
1PSI	Gauge, Differential	Digital output
2PSI	Gauge, Differential	Digital output
5PSI	Gauge, Differential	Digital output
15PSI	Gauge, Differential, Absolute	Digital output
30PSI	Gauge, Differential, Absolute	Digital output
50PSI	Gauge, Differential, Absolute	Digital output
100PSI	Gauge, Differential, Absolute	Digital output
150PSI	Gauge, Differential, Absolute	Digital output
300PSI	Gauge, Differential, Absolute	Digital output

5 mbar	Gauge, Differential	Digital output
10 mbar	Gauge, Differential	Digital output
25 mbar	Gauge, Differential	Digital output
50 mbar	Gauge, Differential	Digital output
5Kpa	Gauge, Differential	Digital output
10Kpa	Gauge, Differential	Digital output
35Kpa	Gauge, Differential	Digital output
100Kpa	Gauge, Differential	Digital output
200Kpa	Gauge, Differential	Digital output

400Kpa	Gauge, Differential	Digital output
1000Kpa	Gauge, Differential	Digital output
2000Kpa	Gauge, Differential	Digital output

## MAXIMUM RATINGS<sup>1</sup>

Parameter	Min	Max	Unit
Supply Voltage (V <sub>supply</sub> )	-0.3	5.5	V <sub>dc</sub>
Voltage on any pin	-0.3	V <sub>supply</sub> +0.3	V
Digital Interface clock frequency:			
I <sup>2</sup> C	100	400	KHZ
SPI	50	800	
ESD susceptibility (Human body mode)		4	Kv
Storage Temperature	-40	125	°C
Soldering time and temperature	5s max, at 250°C 15s max, at 250°C		
Solder temperature (DIP)			
Peak reflow temperature (SMT)			

## OPERATING SPECIFICATIONS

Parameter	Min	Typical	Max	Unit
Supply Voltage (V <sub>supply</sub> )				
3.3	3.0	3.3 <sup>2</sup>	3.6	V <sub>dc</sub>
5.0	4.75	5.0 <sup>2</sup>	5.25	V <sub>dc</sub>
Sensors are either 3.3 V <sub>dc</sub> or 5.0 V <sub>dc</sub> based on listing selected				
Supply current				
3.3 V <sub>dc</sub> supply	3			mA
5.0 V <sub>dc</sub> supply	4.5			mA
Compensated temperature range <sup>3</sup>	-10	-	60	°C
Operating temperature range <sup>4</sup>	-40	-	125	°C
Startup time (power up to data ready)	-	2.8	7.3	ms
Response time	-	0.46	-	ms
I <sup>2</sup> C/SPI voltage level low	-	-	0.2	V <sub>supply</sub>
I <sup>2</sup> C/SPI voltage level high	0.8	-	-	V <sub>supply</sub>
Pull up on SDA/MISO, SCL/SCLK, SS	1	-	-	Kohm
Accuracy <sup>5</sup>	-	-	±0.25	%FSS <sup>7</sup>
Orientation Sensitivity <sup>6</sup>	-	-	±0.15	%FSS <sup>8</sup>
Total Error Band (TEB) <sup>7</sup>	-1%	-	1%	%FSS
Over Pressure		>3		Times

Burst Pressure		>5		Times
OUTPUT RESOLUTION	12	-	16	Bits

## ENVIRONMENT SPECIFICATIONS

Parameter	Characteristic
Humidity: Gases only	0% to 95% RH, non condensing
Vibration	MIL-STD-202F, Method 214, Condition F (20.7 g random)
Shock	MIL-STD-202F, Method 213B, Condition F
Life <sup>9</sup>	1million cycles to working pressure min
Solder reflow	J-STD-020D. Moisture sensitivity level 1

## WETTED MATERIAL<sup>9</sup>

Parameter	PortA (Pressure port)	PortB (Reference)
Cover	PPS or Ceramic	PPS or Ceramic
Substrate	Alumina ceramic or FR4	Alumina Ceramic or FR4
Adhesives	Epoxy, silicone	Epoxy, silicone
Electrical components	Ceramic, solder, silicon	Ceramic, solder, silicon

### Notes:

- Maximum ratings are the extreme limits the device can withstand without damage to the product. Stresses above these ratings may cause permanent damage. Exposure to absolute maximum conditions for extended periods may degrade device reliability.
- The sensor is not reverse polarity protected. Incorrect application of supply voltage or ground to the wrong pin may cause electrical failure.
- The compensated temperature range is the temperature range over which the sensor will produce an output proportional to pressure within the specified performance limits.
- The operating temperature range is the temperature range over which the sensor will produce an output proportional to pressure but may not remain within the specified performance limits.
- Accuracy: The maximum deviation in output from a Best Fit Straight Line (BFSL) fitted to the output measured over the pressure range at 25 °C Includes all errors due to pressure non-linearity, pressure hysteresis, and non-repeatability.
- Orientation sensitivity: The maximum change in offset of the sensor due to a change in position or orientation relative to Earth's gravitational field.
- Total Error Band: The maximum deviation from the ideal transfer function over the entire compensated temperature and pressure range. Includes all errors due to offset, full scale span, pressure non-linearity, pressure hysteresis, repeatability, thermal effect on offset, thermal effect on span, and thermal hysteresis.

8. Full Scale Span (FSS): The algebraic difference between the output signal measured at the maximum (Pmax.) and minimum (Pmin.) limits of the pressure range.
9. Life may vary depending on specific application in which sensor is utilized.
10. Contact Stablesens International Sales and Service for detailed material information.
11. Total Error Band After Auto-Zero: The maximum deviation from the ideal transfer function over the entire compensated pressure range at a constant temperature and supply voltage for a minimum of 24 hours after an auto-zero operation. Includes all errors due to full scale span, pressure non-linearity, pressure hysteresis, and thermal effect on span.
12. Working Pressure: The maximum pressure that may be applied to any port of the sensor in continuous use. This pressure may be outside the operating pressure range limits (Pmin. to Pmax.) in which case the sensor may not provide a valid output until pressure is returned to within the operating pressure range. Tested to 1 million cycles, min.
13. Overpressure: The absolute maximum rating for pressure which may safely be applied to the product for it to remain in specification once pressure is returned to the operating pressure range. Exposure to higher pressures may cause permanent damage to the product. Unless otherwise specified this applies to all available pressure ports at any temperature with the operating temperature range. Tested to 10,000 cycles, minimum.
14. Burst Pressure: The maximum pressure that may be applied to any port of the product without causing escape of pressure media. Product should not be expected to function after exposure to any pressure beyond the burst pressure.
15. Common Mode Pressure: The maximum pressure that can be applied simultaneously to both ports of a differential pressure sensor without causing changes in specified performance.
16. Customized design please contact Stablesens International sales.

## Warning:

### Please follow below instructions to avoid possible product damage

- Make sure fluid only be used for port A, port B is not compatible with liquid, need contact customer service for liquid compatibility customization for port B.
- Make sure liquid fluid do not contain particles. All SAS58 sensor is connected to sealed device, the particles will accumulate inside the sensor and cause device damage or impact the sensor output. Suggest to place the port A upside down so the particles in the system will not enter into port A and will not stay in the sensor.
- Make sure the liquid fluid will not cause any residual after dry out, accumulated residuals may impact the sensor output, it is very hard to clean and remove the residuals.

## BLOCK DIAGRAM

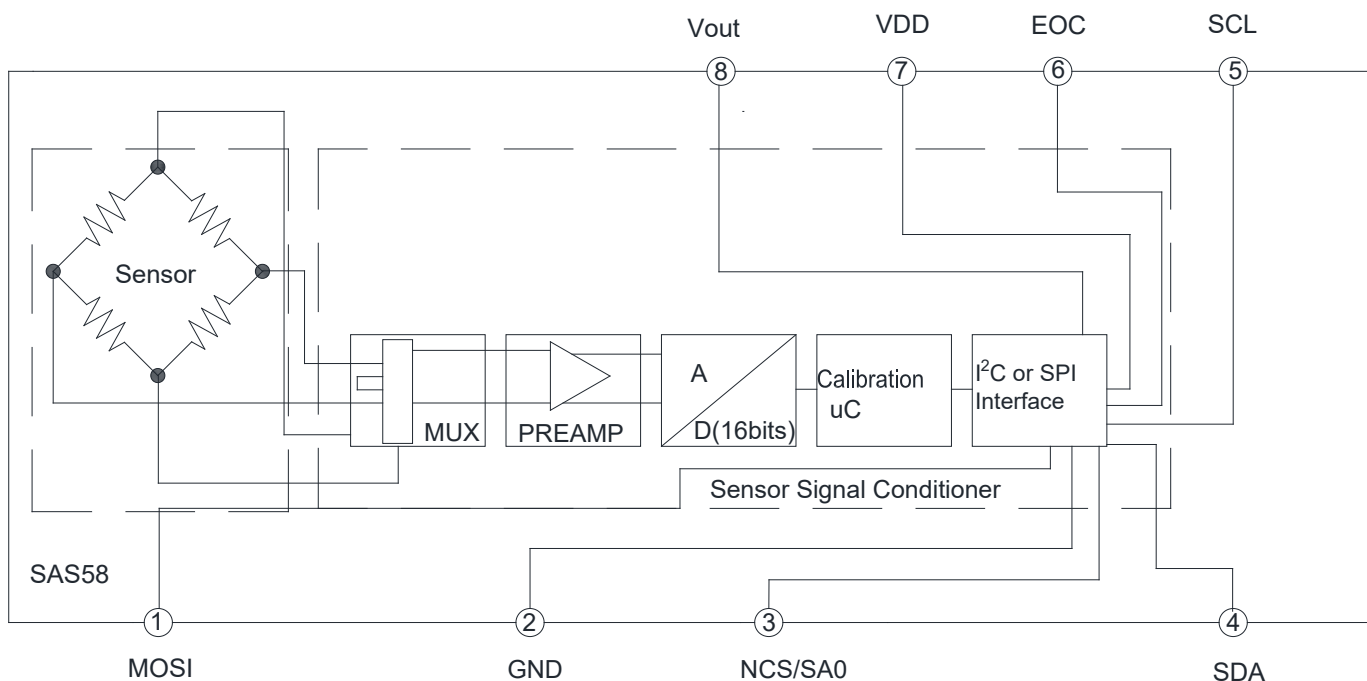

## PRESSURE AND TEMPERATURE TRANSFER

压力转换方程

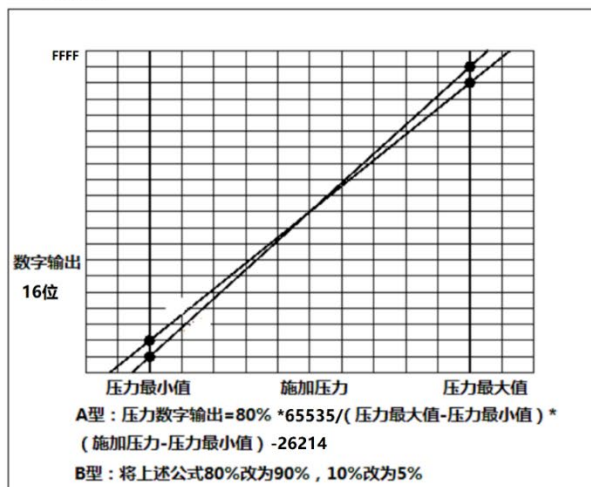

温度转换方程

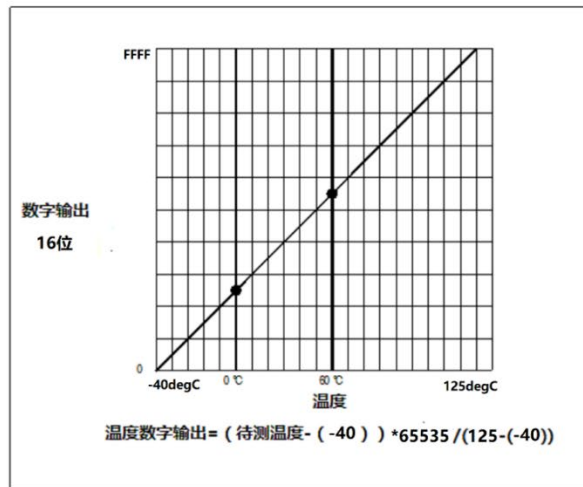

### I2C or SPI Digital Output

压力转换方程, 电压输入5V

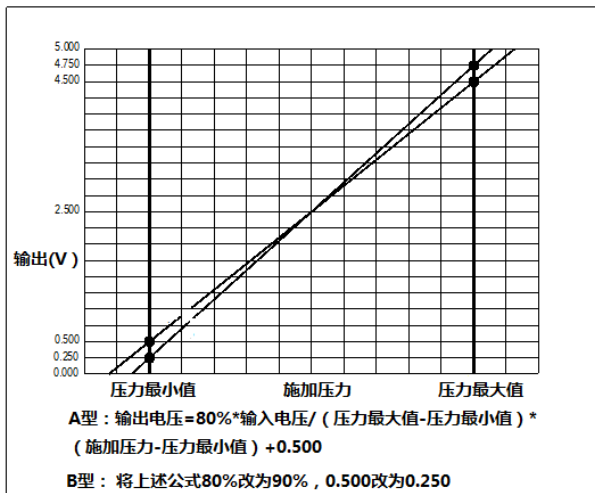

压力转换方程, 电压输入 3.3V

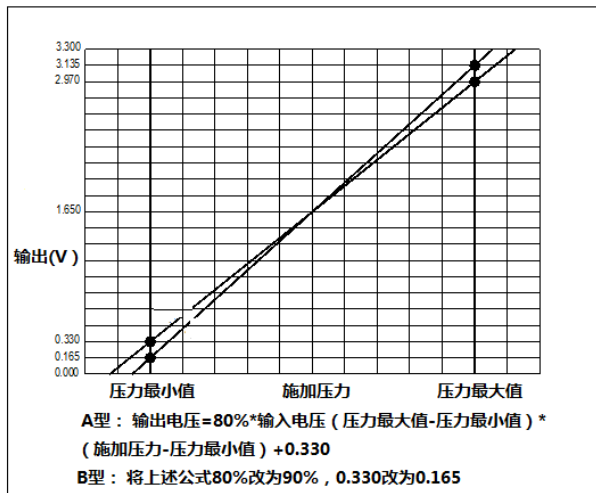

Analog Output

PRESSURE TYPES

Pressure type	Comments
Gauge	Output is proportional to the difference between applied pressure and atmospheric (ambient) pressure. Pmin. is set at atmospheric pressure.
Differential	Output is proportional to the difference between the pressures applied to each port (Port A ~Port B). 50% point of transfer function set at Port A = Port B.
Absolute	Output is proportional to the difference between applied pressure and absolute zero pressure pressure. Pmin. is set at absolute zero pressure.

SENSOR OUTPUT AT SIGNIFICANT PERCENTAGES

% Output	Digital Counts (decimal)	Analog (5VPower)	Analog (3.3VPower)
0	-32768	0	0
5	-29491	0.25	0.165
10	-26214	0.5	0.33
50	0	2.5	1.65
90	26214	4.5	2.97
95	29491	4.75	3.135
100	32768	5	3.3

CONNECTION DIAGRAM

Pin#	1	2	3	4	5	6	7	8
Analog	MOSI	GND	NCS/SA 0	SDA	SCL	EOC	VDD	Vout
I2C	MOSI	GND	NCS/SA 0	SDA	SCL	EOC	VDD	Vout
SPI	MOSI	GND	NCS/SA 0	MISO	SCLK	EOC	VDD	Vout

DIMENSION DRAWING ( INCH [ MILLIMETER ] )

METAL TUBE  
CERAMIC SUBSTRATE

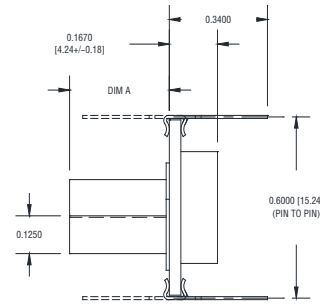
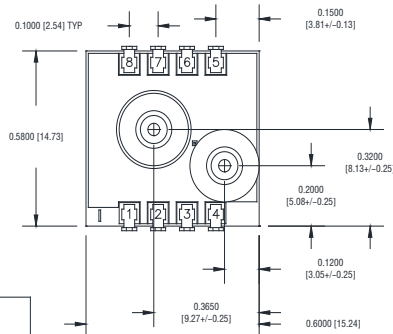

VENT TUBE DIMENSIONS	
MODEL	DIM A
1N/3N	N/A
1L/3L	.490+/- .005 [12.45+/-0.13]
1S/3S	.325+/- .005 [8.26+/-0.13]

PLASTIC TUBE W/ BARB  
FR4 SUBSTRATE

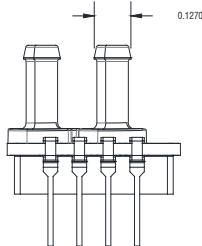
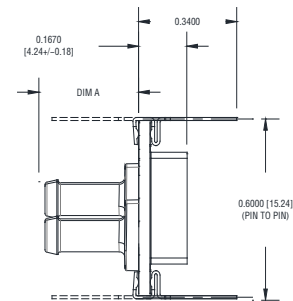
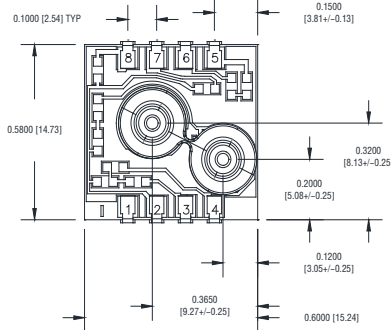

NOTES:

-Port A is always given positive pressure during calibration.

# ORDERING INFORMATION

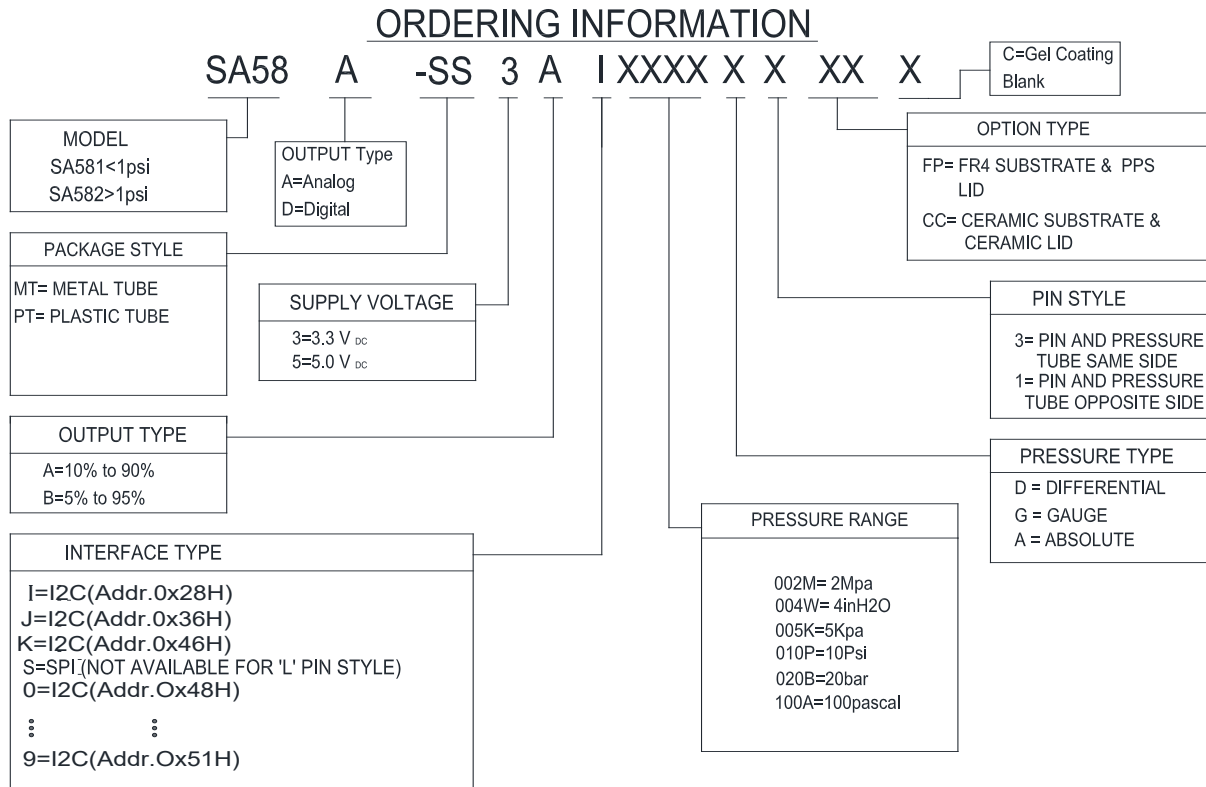

# I2C COMMUNICATION SPECIFICATIONS AND CODE EXAMPLE

## 1: Electrical table

Item	Description	Condition	Symbol	Min	Typ	Max	Unit
1	SDA output low voltage	$I_{SDA} = 3 \text{ mA}$	$V_{SDA,OL}$	0		0.4	V
2	Low-to-High transition threshold	pins SA0, SCL	$V_{SDA,LH}$	0.5	0.6	0.7	*VDD
3	High-to-Low transition threshold	pins SA0, SCL	$V_{SDA,HL}$	0.3	0.4	0.5	*VDD
4	I <sup>2</sup> C clock frequency		fSCL	0		400	kHz
5	Bus free time between a START and STOP condition		tBUSF	1300			ns
6	Clock low time		tLO	1300			ns
7	Clock high time		tHI	600			ns
8	START condition hold time		tSH	100			ns
9	Data setup time		tSU	100			ns
10	Data hold time		tH	0			ns
11	Setup time for repeated START condition		tRSH	600			ns
12	Setup time for STOP condition		tPSU	600			ns
13	Rise time of SDA and SCL signals		tR			300	ns
14	Fall time of SDA and SCL signals		tF			300	ns

## 2: I<sup>2</sup>C Interface

The SQMEAS pressure sensor features an I<sup>2</sup>C slave interface. This interface provides direct access to registers of the memory of the pressure sensor. An external I<sup>2</sup>C master (e.g. a microcontroller) can read from and write to memory addresses (registers) of the device using the following commands:

- Random write:** Sets a memory address and writes data to consecutive memory addresses of the device starting at the set memory address.
- Random read:** Sets a memory address and reads data from consecutive memory addresses of the device starting at the set memory address.
- Read last:** Reads data from the device starting at the last memory address set by the master. This facilitates repeated reading of the same memory addresses without transmitting a memory address first.

All reads/writes must start at word aligned addresses (i.e. LSB of memory address equals 0) and read/write an even number of bytes.

## 3. I<sup>2</sup>C Command Format

The SQMEAS pressure sensor uses a standard 7-bit I<sup>2</sup>C slave address field. The LSB of the slave address specifies the frame type used to perform read and write operations.

For LSB = 0 the protocol is compatible to standard I<sup>2</sup>C EEPROMs, for LSB = 1 the protocol is extended by a CRC protection. Thus, each device occupies two I<sup>2</sup>C addresses: even addresses are for standard EEPROM compatible protocols and odd addresses are for CRC protected protocols. Unprotected and CRC protected frames can be interleaved. The two different frame types - standard EEPROM (without CRC) or CRC protected - are shown in the next two figures.

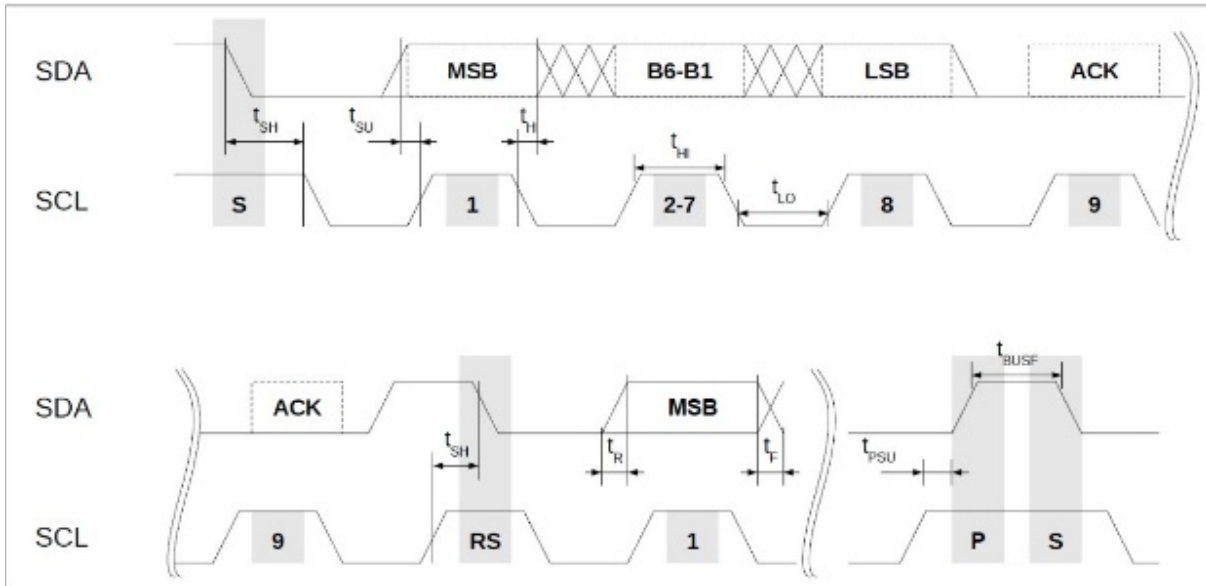

Figure 1: I<sup>2</sup>C Interface

Timing Diagram

Random write



Random read



Read last



Legend

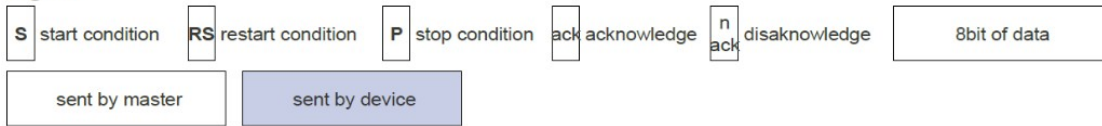
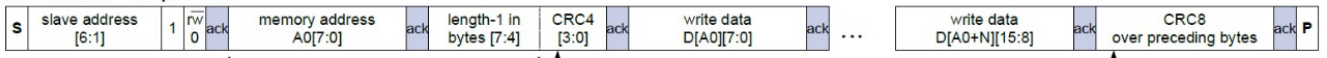
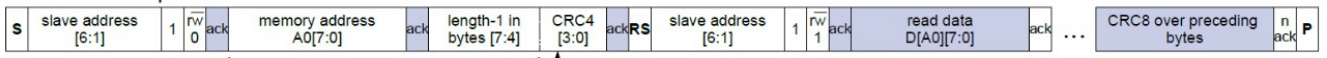

Figure 2: I<sup>2</sup>C Read / Write Commands - Standard EEPROM compatible protocol

Random write - CRC protected



Random read - CRC protected



Read last - CRC protected (reads the same number of data bytes as the previous read/write)

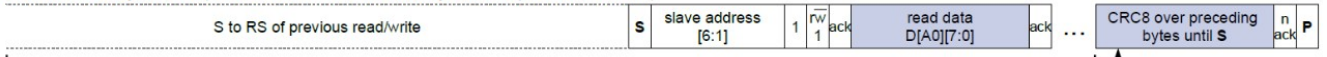

Legend

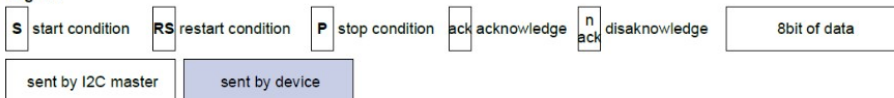

Figure 3: I<sup>2</sup>C Read / Write Commands - CRC protected protocol

The memory address field sets the byte address of the first memory location to be read from or written to. Only 16-bit-word aligned reads/writes are supported, i.e. the LSB of memory address has to be always

zero. The read/write data is transferred MSB first, low byte before high byte.

The length field (bits[7:4]) required for CRC protected frames specifies the number of data bytes to be transferred decremented by one, i.e. a value of 0001b corresponds to two bytes. All frames must transfer an even number of bytes. The maximum length for CRC protected read/write frames is 16/4 bytes. For unprotected frames the length is unlimited.

The CRC4 and CRC8 for redundancy check are computed in the same bit and byte order as the transmission over the bus. The polynomials employed are:

CRC4: polynomial 0x03;

initialization value: 0x0F

CRC8: polynomial 0xD5;

initialization value: 0xFF

If a CRC error occurs, then the event bit “com\_crc\_error” in the STATUS register will be set.

#### 4. I<sup>2</sup>C Command Examples

For all examples below the 7-bit device slave address used is 0x6C for unprotected commands, and 0x6D for CRC protected commands, respectively. These addresses are the default addresses and are used unless otherwise stated in the part number specific data sheet.

The command sequence following describes an unprotected Read command (without CRC) of 3 subsequent 16-bit words starting at memory address 0x2E to read the corrected IC temperature, corrected pressure signal, and (synchronized) status bits of the sensor.

##### Random Read

Byte#	0	1	2	3	4	5	6	7	8
<b>SBM</b> (sent by master)	0xD8	0x2E	0xD9						
<b>SBM comment</b>	slave address 6C + LSB = 0 for Write	memory address	slave address 6C + LSB = 1 for Read						
<b>SBS</b> (sent by sensor)				0xF2	0x7D	0xEA	0x82	0x1E	0x00
<b>SBS comment</b>				DSP_T (Lo-Byte) ad. 0x2E	DSP_T (Hi-Byte)	DSP_S (Lo-Byte) ad. 0x30	DSP_S (Hi-Byte)	sync'ed Status (b7 - b0) ad. 0x32	sync'ed Status (b15 - b8)

##### Random read with CRC protection

The following sequence describes the CRC protected version of reading 3 subsequent 16-bit words starting at memory address 0x2E to read the corrected IC temperature, corrected pressure signal, and (synchronized) status bits of the sensor.

Byte#	0	1	2	3	4	5	6	7	8	9	10
-------	---	---	---	---	---	---	---	---	---	---	----

<b>SBM</b> (sent by master)	0xDA	0x2E	0x5B	0xDB								
<b>SBM comment</b>	slave address 6D + LSB = 0 for Write	memory address	3: length = 4Byte B: CRC4	slave address 6D + LSB = 1 for Read								
<b>SBS</b> (sent by sensor)					0xF2	0x7D	0xEA	0x82	0x1E	0x00	0x65	
<b>SBS comment</b>					DSP_T (Lo-Byte) ad. 0x2E	DSP_T (Hi-Byte)	DSP_S (Lo-Byte) ad. 0x30	DSP_S (Hi-Byte)	sync'ed Status (b7 - b0) ad. 0x32	sync'ed Status (b15 - b8)	CRC8 (calc'd)	

The following sequence writes one 16-bit word to address 0x22 (without CRC protection). This will copy 0x6C32 into the command register CMD to move the component to Sleep Mode.

#### Random Write:

Byte#	0	1	2	3
<b>SBM</b> (sent by master)	0xD8	0x22	0x32	0x6C
<b>SBM comment</b>	slave address 6C + LSB = 0 for Write	memory address	Lo-Byte written to CMD[7:0]	Hi-Byte written to CMD[15:8]
<b>SBS</b> (sent by sensor)				
<b>SBS comment</b>				

## 5. Register Descriptions

Register Read or Write are performed via the digital communication interface. After power-up of the IC all registers except STATUS and CMD are write protected.

Command register:

0X22	CMD			
bits	name	default	rw	description
15:0	cmd	0	w	Writing to this register controls the state of the BAP device. 0x6C32: SLEEP Mode Initiate the power state SLEEP, powering down the ASIC 0xB169: RESET Performs a reset. After reset the power-up sequence will be executed, i.e. the registers are loaded with data from the configuration memory, also a CRC check is performed.

Temperature register:

0X2E	DSP_T			
bits	name	default	rw	description
15:0	Dsp_T		r	Corrected temperature measurement value of the sensor. Whenever this register is updated with a new measurement the STATUS.dsp_t_up event bit is set.

Pressure register:

0X30	DSP_P			
bits	name	default	rw	description
15:0	Dsp_P		r	corrected pressure measurement value of the sensor. Whenever this register is updated with a new measurement the STATUS.dsp_s_up event bit is set.

The registers DSP\_T and DSP\_S contain invalid data after power-up until the first temperature and pressure values have been measured by the device and transferred to these registers. In case a NVM CRC error occurred, the DSP\_T and DSP\_S registers would never be updated. **Thus, after power up it is necessary to wait until the STATUS.dsp\_s\_up and dsp\_t\_up bits have been set at least once before using the temperature or pressure data.**

**It is not sufficient to wait just for a fixed time delay.**

## Status register - synchronized:

0X32	Status_sync				
bits	name	default	rw	type	description
0	idle	0	rw	status	STATUS.idle
1	- reserved -	0	rw	event	reserved
2	- reserved -	0	rw	event	reserved
3	dsp_s_up	0	rw	event	when DSP_S is read STATUS.dsp_s_up is copied here
4	dsp_t_up	0	rw	event	when DSP_T is read STATUS.dsp_t_up is copied here
5	- reserved -	0	rw	status	reserved
6	- reserved -	0	rw	status	reserved
7	bs_fail	0	rw	event	STATUS.bs_fail
8	bc_fail	0	rw	event	STATUS.bc_fail
9	- reserved -	0	rw	event	reserved
10	dsp_sat	0	rw	status	STATUS.dsp_sat
11	com_crc_error	0	rw	event	STATUS.com_crc_error
12	- reserved -	0	rw	status	reserved

13	- reserved -	0	rw	status	reserved
14	dsp_s_missed	0	rw	event	STATUS.dsp_s_missed
15	dsp_t_missed	0	rw	event	STATUS.dsp_t_missed

The bits STATUS\_SYNC[15:5,0] are identical to the bits STATUS[15:5,0].

The bits STATUS\_SYNC[4:3] are copied from the STATUS register when the corresponding DSP registers are read. First reading the DSP registers and then STATUS\_SYNC ensures that both values are consistent to each other.

**The synchronized status STATUS\_SYNC register can be used to continuously poll the pressure, temperature and status of the device with a single read command by reading three 16 bit words starting at address 0x2E.** By evaluating STATUS\_SYNC.dsp\_t\_up and STATUS\_SYNC.dsp\_s\_up it can be determined if the values in DSP\_T and DSP\_S acquired during the same read contain recently updated temperature or pressure values.

### Status register:

0X36	Status				
bits	name	default	rw	<sup>1</sup> type	description
0	idle	0	rw	status	0: chip in busy state 1: chip in idle state
1	- reserved -	0	rw	event	reserved
2	- reserved -	0	rw	event	reserved
3	dsp_s_up	0	rw	event	1: DSP_S register has been updated. Cleared when DSP_S is read
4	dsp_t_up	0	rw	event	1: DSP_T register has been updated. Cleared when DSP_T is read.
5	- reserved -	0	rw	status	reserved
6	- reserved -	0	rw	status	reserved
7	bs_fail	0	rw	event	1: bridge supply failure occurred
8	bc_fail	0	rw	event	1: sensor bridge check failure occurred
9	- reserved -	0	rw	event	reserved
10	dsp_sat	0	rw	status	1: a DSP computation leading to the current DSP_T or DSP_S values was saturated to prevent overflow
11	com_crc_error	0	rw	event	1: communication CRC error
12	- reserved -	0	rw	status	reserved
13	- reserved -	0	rw	status	reserved
14	dsp_s_missed	0	rw	event	1: dsp_s_up was 1 when DSP_S updated
15	dsp_t_missed	0	rw	event	1: dsp_t_up was 1 when DSP_T updated

1)"Event" type flags remain set until cleared by writing '1' to the respective bit position in STATUS register (not STATUS\_SYNC). Writing 0xFFFF to the STATUS register will clear all event bits. "Status" type flag represents a condition of a hardware module of the IC and persists until the condition has disappeared.

## 6. I2C Examples

```

/*****
* Function Name : SKATER_I2C_MultRead
* Description  : 多字节写读取指定地址的数据（7位地址）。
* Input       : - pBuffer: 数据存储区。
*             - I2C_SLAVE_ADDRESS : 设备地址。
*             - RegAddr:起始寄存器地址。
*             - NumByteToRead: 连续读取的字节数目。
* Output      : None
* Return      : None
*****/
void I2C_MutiRead(uint8_t* data, uint8_t dev, uint8_t reg,uint8_t NumByteToRead)
{
    uint8_t count=0;

    IIC_Start();//产生一个起始条件
    IIC_Send_Byte(dev); //发送写命令
    IIC_Wait_Ack();//应答
    IIC_Send_Byte(reg); //发送地址
    IIC_Wait_Ack(); //应答
    IIC_Start();//产生一个起始条件
    IIC_Send_Byte(dev+1); //进入接收模式
    IIC_Wait_Ack();//应答

    for(count=0;count<NumByteToRead;count++){

        if(count!=NumByteToRead-1)data[count]=IIC_Read_Byte(1); //带 ACK 的读数据
        else data[count]=IIC_Read_Byte(0); //最后一个字节 NACK
    }
    IIC_Stop();//产生一个停止条件
    return ;
}

float GetPa(void)
{
    uint8_t data[6]={0};
    int16_t PaD=0,Temp=0;
    float Per[6]={0},Psum=0,Pmax=-1000,Pmin=1000;//Psum 总和, Pmax: 最大压力
    值, Pmin: 最小压力值
    Pa_flag=0;
    for(uint8_t i=0;i<4;i++)
    {
        // HAL_I2C_Mem_Read(&hi2c1,0xD8, 0x2E,
    I2C_MEMADD_SIZE_8BIT,data, 6, 1000);
        I2C_MutiRead(data, 0xD8,0x2E,6);//读取传感器数据放到 data 里, data:
    数据 buff、 0xD8: 从地址, 0x2E: 温度寄存器地址, 6: 连续读 6 个;

```

```

Temp=(data[1]<<8)+data[0];//温度: data[1]: 数据高 8 位, data[0]: 数据
低 8 位

PaD=(data[3]<<8)+data[2];           //压力大小, 高地址+低地址
Per[i]=(-500.0+(PaD+26214)*1000.0/52428)*1.0; //6895
if(Per[i]>Pmax)
    Pmax=Per[i];
if(Per[i]<Pmin)
    Pmin=Per[i];
Psum+=Per[i];
}
Pa=(Psum-Pmax-Pmin)/2-FlashParameter.Offset;

Tempr=-40-2+(Temp+32768)*165/65535;           //2 度偏差
Pa_flag=1;
if(FlashParameter.Range==1)                   //40-50Pa
{
    if(fabs(Pa)>=50)
        Alarm=1;
    else if(fabs(Pa)<=40)
        Alarm=0;
}
else //25-30Pa
{
    if(fabs(Pa)>=30)
        Alarm=1;
    else if(fabs(Pa)<=25)
        Alarm=0;
}
return Pa;
}

```