

MODEL SAS85C-XXXXXX-XX SAS85C-XXXXXX-XX(T)

(DCN XXXXX)

Doc No.: OD-SAS85
(Rev.A/ 2023-08-10)
Sh 1 of 10

THIRD ANGLE PROJECTION

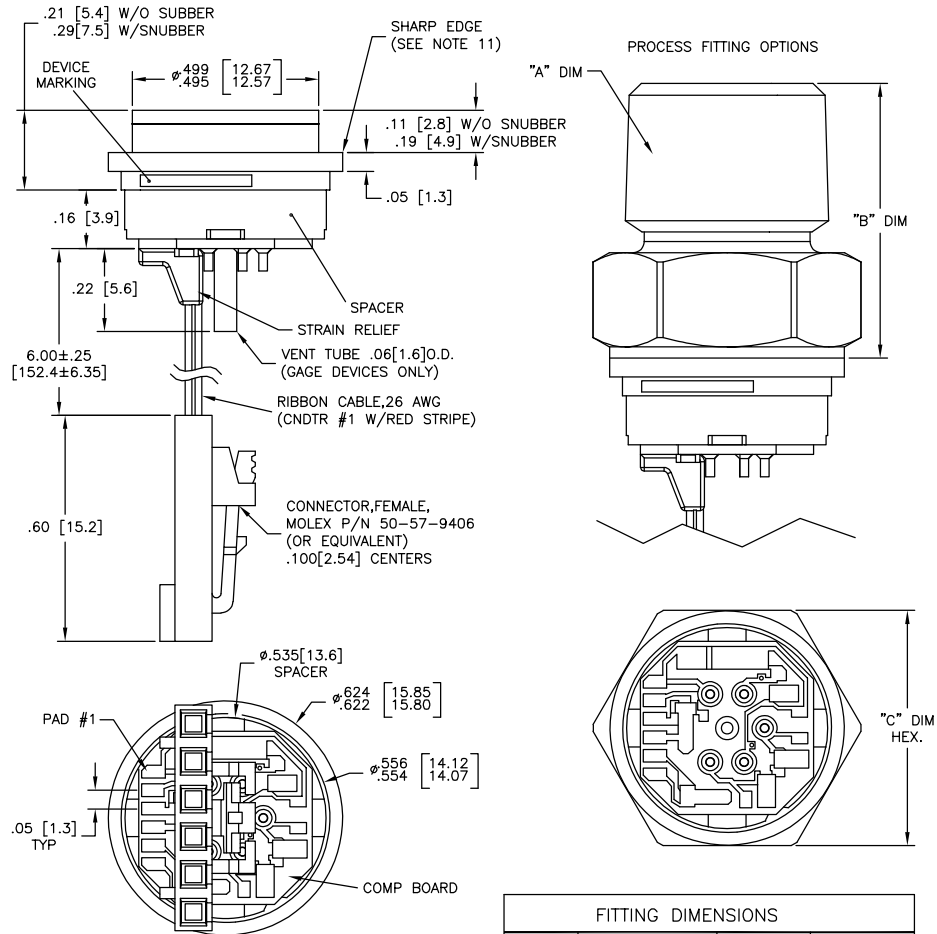
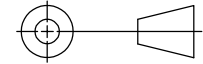

UNLESS OTHERWISE SPECIFIED:
ALL PARAMETERS ARE MEASURED AT 1.5mA AND AT 25°C

PARAMETERS	005 PSI			≥015PSI			UNITS	NOTES
	MIN	TYP	MAX	MIN	TYP	MAX		
SPAN	50	100	150	75	100	150	mV	1
ZERO PRESSURE OUTPUT	-2.0	0	+2.0	-1.0	0	+1.0	mV	2
PRESSURE NON-LINEARITY	-0.20	-	+0.20	-0.10	-	+0.10	% SPAN	3
PRESSURE HYSTERESIS	-0.10	±0.02	+0.10	-0.05	±0.02	+0.05	% SPAN	
REPEATABILITY	-	±0.02	-	-	±0.02	-	% SPAN	
INPUT RESISTANCE	2.5K	5.0K	6.5K	2.0K	3.5K	5.8K	Ω	
OUTPUT RESISTANCE	4.0K	-	7.0K	4.0K	-	6.0K	Ω	
TEMPERATURE ERROR, SPAN	-1.0	-	+1.0	-0.75	-	+0.75	% SPAN	4
TEMPERATURE ERROR, OFFSET	-2.5	-	+2.5	-0.50	-	+0.50	% SPAN	4,5
THERMAL HYSTERESIS, SPAN	-0.25	±0.05	+0.25	-0.25	±0.05	+0.25	% SPAN	4
THERMAL HYSTERESIS, OFFSET	-0.25	±0.05	+0.25	-0.25	±0.05	+0.25	% SPAN	4
LONG TERM STABILITY, SPAN	-	±0.10	-	-	±0.10	-	% SPAN/YR	
LONG TERM STABILITY, OFFSET	-	±0.25	-	-	±0.10	-	% SPAN/YR	
SUPPLY CURRENT	0.5	1.5	2.0	0.5	1.5	2.0	mA	6
OUTPUT LOAD RESISTANCE	5M	-	-	5M	-	-	Ω	7
INSULATION RESISTANCE (50 VDC)	50M	-	-	50M	-	-	Ω	8
OUTPUT NOISE (10Hz to 1kHz)	-	1.0	-	-	1.0	-	μV p-p	
RISE TIME (10% to 90%)	-	-	0.1	-	-	0.1	mS	
PROOF PRESSURE	-	-	3X	-	-	3X	RATED	
BURST PRESSURE	-	-	4X	-	-	4X	RATED	9
COMPENSATED TEMPERATURE	0	-	+50	-20	-	+85	°C	
OPERATING TEMPERATURE	-20	-	+70	-40	-	+125	°C	10
STORAGE TEMPERATURE	-50	-	+125	-50	-	+125	°C	10
MEDIA, PRESSURE PORT	LIQUIDS AND GASES COMPATIBLE WITH 316/316L ST STL							
MEDIA, REFERENCE PORT	LIQUIDS AND GASES COMPATIBLE WITH SILICONE, PYREX, GOLD, FLUOROSILICONE RUBBER AND 316/316L ST STL							

ORDERING INFORMATION

SAS85C-XXX X X X - X X

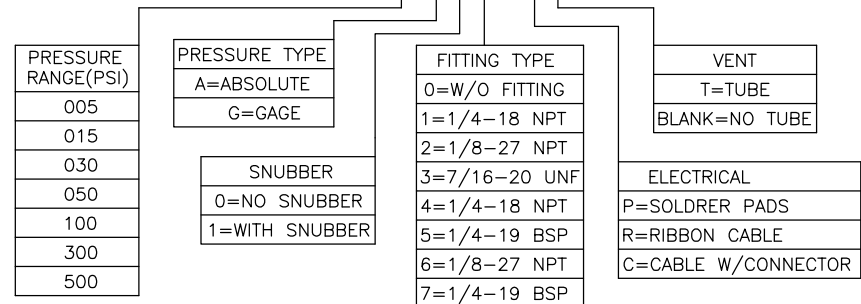

PAD/CNDR	FUNCTION
1	+OUT
2	-EX
3	+EX
4	-OUT
5	GAIN
6	

FITTING DIMENSIONS			
FITTING TYPE	"A" DIM	"B" DIM	"C" DIM
1	1/4-18 NPT	.99[25.1]	7/8[22.2]
2	1/8-27 NPT	.96[24.4]	7/8[22.2]
3	7/16-20 UNF	.81[20.6]	7/8[22.2]
4	1/4-18 NPT	.73[18.5]	5/8[15.9]
5	1/4-19 BSP	.76[19.3]	3/4[19.0]
6	1/8-27 NPT	.60[15.2]	5/8[15.9]
7	1/4-19 BSP	.94[23.9]	7/8[22.2]

NOTE: FTG TYPE "4" ASSEMBLY SHOWN
ALL DIMS FOR REFERENCE

DIMENSIONS ARE IN INCHES

TOLERANCES (UNLESS SPECIFIED)

XX=.01
XXX=.005
ANGLES=1/2°

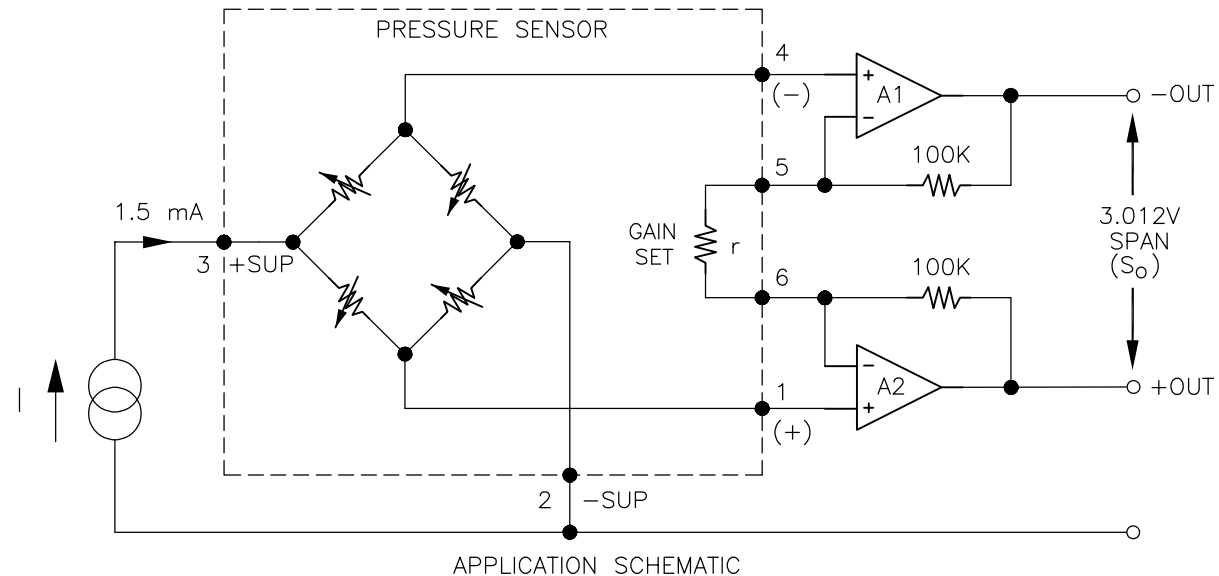

APPLICATION SCHEMATIC

NOTES:

1. FOR AMPLIFIED OUTPUT CIRCUITS, 3.012V \pm 1% INTERCHANGEABILITY WITH GAIN SET RESISTOR. SEE APPLICATION SCHEMATIC.
2. MEASURED AT VACUUM FOR ABSOLUTE (A), AMBIENT FOR GAGE (G).
3. BEST FIT STRAIGHT LINE.
4. OVER THE COMPENSATED TEMPERATURE RANGE WITH RESPECT TO 25°C.
5. 15 PSI RANGES SENSORS HAVE A TEMPERATURE ERROR- OFFSET AS \pm 0.75% (MAX).
6. GUARANTEES OUTPUT/INPUT RATIOMETRICITY.
7. LOAD RESISTANCE TO REDUCE MEASUREMENT ERRORS DUE TO OUTPUT LOADING.
8. BETWEEN CASE AND SENSING ELEMENT.
9. THE MAXIMUM PRESSURE THAT CAN BE APPLIED TO A TRANSDUCER WITHOUT RUPTURE OF EITHER THE SENSING ELEMENT OR TRANSDUCER
10. MAXIMUM TEMPERATURE RANGE FOR PRODUCT WITH STANDARD CABLE AND CONNECTOR IS -20°C TO +105°C.
11. SHARP EDGE STRONGLY RECOMMENDED FOR WELDING APPLICATION. OPTIUM WELD PARAMETERS WILL REDUCE THE EFFECT OF WELD HEAT ON SENSOR PERFORMANCE. DEVICES WITH LOWER PRESSURE RANGES HAVE GREATER SUSCEPTIBILITY TO HEAT GENERATED DURING THE WELD PROCESS.
12. STANDARD GAGE UNITS ARE NOT RECOMMENDED FOR VACUUM APPLICATIONS.
FOR VACUUM APPLICATIONS BELOW 1/2 ATMOSPHERE, CONSULT FACTORY.
13. DEVICE MARKING:
EACH PART SHALL BE IDENTIFIED WITH MODEL NUMBER, PRESSURE RANGE, TYPE (GAGE OR ABSOLUTE),
LOT NUMBER, SERIAL NUMBER AND DATE CODE.
14. SHIPPING/PACKAGING REQUIREMENTS:
THE STAINLESS STEEL DIAPHRAGM IS PROTECTED BY A PLASTIC CAP. EACH UNIT WILL BE PACKAGED INDIVIDUALLY IN A PLASTIC VIAL WITH ANTI-STATIC FOAM.
15. DIRECT MECHANICAL CONTACT WITH DIAPHRAGM IS PROHIBITED, DIAPHRAGM SURFACE MUST REMAIN FREE OF DEFECTS (SCRATCHES, PUNCTURES, DENTS, FINGERPRINTS, ECT) FOR DEVICE TO OPERATE PROPERLY. CAUTION IS ADVISED WHEN HANDLING PARTS WITH EXPOSED DIAPHRAGM. USE PROTECTIVE CAP WHENEVER DEVICES ARE NOT IN USE.

MODEL SAS85CV-XXXXXX-XX SAS85CV-XXXXXX-XX(T)

(DCN XXXXX)

Doc No.: OD-SAS85
(Rev.A/ 2023-08-10)
Sh 3 of 10

THIRD ANGLE PROJECTION

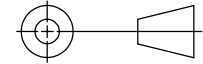

UNLESS OTHERWISE SPECIFIED:
ALL PARAMETERS ARE MEASURED AT 10 VDC AND
AT 25°C AFTER 10 SEC WARM UP

PARAMETERS	005 PSI			≥015PSI			UNITS	NOTES
	MIN	TYP	MAX	MIN	TYP	MAX		
SPAN	98	100	102	99	100	101	mV	1
ZERO PRESSURE OUTPUT	-2.0	0	+2.0	-1.0	0	+1.0	mV	2
PRESSURE NON-LINEARITY	-0.20	-	+0.20	-0.10	-	+0.10	% SPAN	3
PRESSURE HYSTERESIS	-0.10	±0.02	+0.10	-0.05	±0.02	+0.05	% SPAN	
REPEATABILITY	-	±0.02	-	-	±0.02	-	% SPAN	
INPUT RESISTANCE	5.5K	9.0K	12.5K	5.5K	9.0K	12.5K	Ω	
OUTPUT RESISTANCE	4.0K	-	7.0K	4.0K	-	6.0K	Ω	
TEMPERATURE ERROR, SPAN	-1.5	-	+1.5	-1.0	-	+1.0	% SPAN	3
TEMPERATURE ERROR, OFFSET	-2.5	-	+2.5	-1.0	-	+1.0	% SPAN	3
THERMAL HYSTERESIS, SPAN	-0.25	±0.05	+0.25	-0.25	±0.05	+0.25	% SPAN	3
THERMAL HYSTERESIS, OFFSET	-0.25	±0.05	+0.25	-0.25	±0.05	+0.25	% SPAN	3
LONG TERM STABILITY, SPAN	-	±0.10	-	-	±0.10	-	% SPAN/YR	
LONG TERM STABILITY, OFFSET	-	±0.25	-	-	±0.10	-	% SPAN/YR	
SUPPLY VOLTAGE	-	10	14	-	10	14	VDC	4
OUTPUT LOAD RESISTANCE	5M	-	-	5M	-	-	Ω	5
INSULATION RESISTANCE (50 VDC)	50M	-	-	50M	-	-	Ω	6
OUTPUT NOISE (10Hz to 1kHz)	-	1.0	-	-	1.0	-	μV p-p	
RISE TIME (10% to 90%)	-	-	0.1	-	-	0.1	mS	
PROOF PRESSURE	-	-	3X	-	-	3X	RATED	
BURST PRESSURE	-	-	4X	-	-	4X	RATED	7
COMPENSATED TEMPERATURE	0	-	+50	-20	-	+85	°C	
OPERATING TEMPERATURE	-20	-	+70	-40	-	+125	°C	8
STORAGE TEMPERATURE	-50	-	+125	-50	-	+125	°C	8
MEDIA, PRESSURE PORT	LIQUIDS AND GASES COMPATIBLE WITH 316/316L ST STL							
MEDIA, REFERENCE PORT	LIQUIDS AND GASES COMPATIBLE WITH SILICONE, PYREX, GOLD, FLUOROSILICONE RUBBER AND 316/316L ST STL							

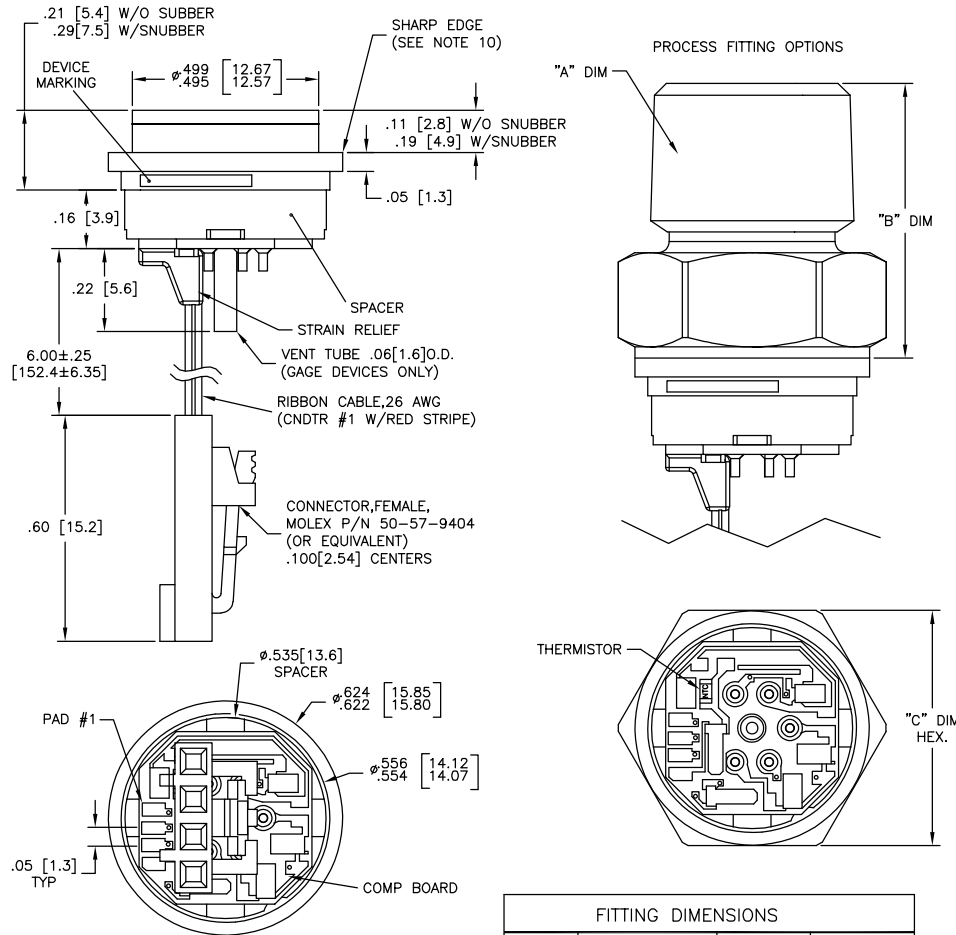

PAD/CNDR	FUNCTION
1	-OUT
2	+OUT
3	-EX
4	+EX

FITTING DIMENSIONS			
FITTING TYPE	"A" DIM	"B" DIM	"C" DIM
1	1/4-18 NPT	.99[25.1]	7/8[22.2]
2	1/8-27 NPT	.96[24.4]	7/8[22.2]
3	7/16-20 UNF	.81[20.6]	7/8[22.2]
4	1/4-18 NPT	.73[18.5]	5/8[15.9]
5	1/4-19 BSP	.76[19.3]	3/4[19.0]
6	1/8-27 NPT	.60[15.2]	5/8[15.9]
7	1/4-19 BSP	.94[23.9]	7/8[22.2]

NOTE: FTG TYPE "4" ASSEMBLY SHOWN
ALL DIMS FOR REFERENCE

ORDERING INFORMATION

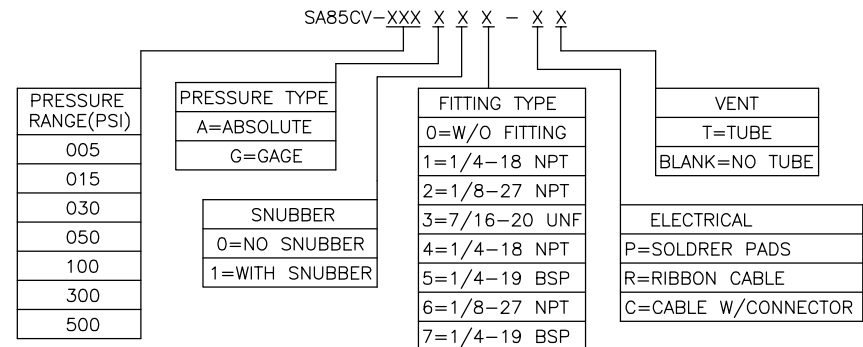

DIMENSIONS ARE IN INCHES
TOLERANCES (UNLESS SPECIFIED)
XX=.01
XXX=.005
ANGLES=1/2°

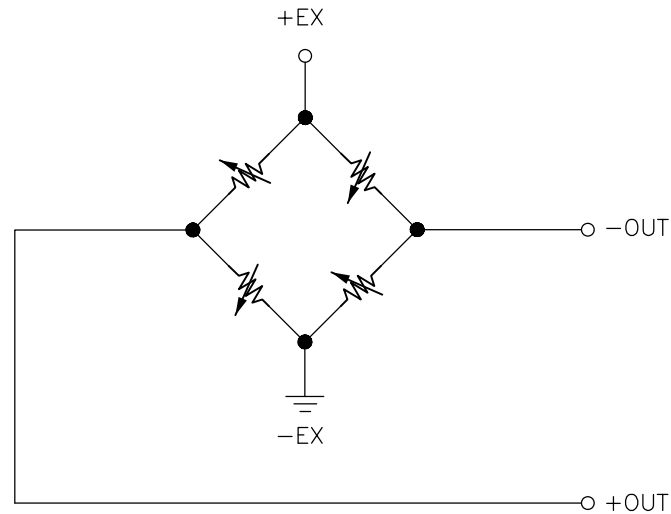

EQUIVALENT SCHEMATIC

NOTES:

1. MEASURED AT VACUUM FOR ABSOLUTE (A), AMBIENT FOR GAGE (G).
2. BEST FIT STRAIGHT LINE.
3. OVER THE COMPENSATED TEMPERATURE RANGE WITH RESPECT TO 25°C.
4. GUARANTEES OUTPUT/INPUT RATIOMETRICITY.
5. LOAD RESISTANCE TO REDUCE MEASUREMENT ERRORS DUE TO OUTPUT LOADING.
6. BETWEEN CASE AND SENSING ELEMENT.
7. THE MAXIMUM PRESSURE THAT CAN BE APPLIED TO A TRANSDUCER WITHOUT RUPTURE OF EITHER THE SENSING ELEMENT OR TRANSDUCER
8. MAXIMUM TEMPERATURE RANGE FOR PRODUCT WITH STANDARD CABLE AND CONNECTOR IS -20°C TO +105°C.
9. STANDARD GAGE UNITS ARE NOT RECOMMENDED FOR VACUUM APPLICATIONS.
FOR VACUUM APPLICATIONS BELOW 1/2 ATMOSPHERE, CONSULT FACTORY.
10. SHARP EDGE STRONGLY RECOMMENDED FOR WELDING APPLICATION. OPTIUM WELD PARAMETERS WILL REDUCE THE EFFECT OF WELD HEAT ON SENSOR PERFORMANCE. DEVICES WITH LOWER PRESSURE RANGES HAVE GREATER SUSCEPTIBILITY TO HEAT GENERATED DURING THE WELD PROCESS.
11. DEVICE MARKING:
EACH PART SHALL BE IDENTIFIED WITH MODEL NUMBER, PRESSURE RANGE, TYPE (GAGE OR ABSOLUTE), LOT NUMBER, SERIAL NUMBER AND DATE CODE.
12. SHIPPING/PACKAGING REQUIREMENTS:
THE STAINLESS STEEL DIAPHRAGM IS PROTECTED BY A PLASTIC CAP. EACH UNIT WILL BE PACKAGED INDIVIDUALLY IN A PLASTIC VIAL WITH ANTI-STATIC FOAM.
13. DIRECT MECHANICAL CONTACT WITH DIAPHRAGM IS PROHIBITED, DIAPHRAGM SURFACE MUST REMAIN FREE OF DEFECTS (SCRATCHES, PUNCTURES, DENTS, FINGERPRINTS, ECT) FOR DEVICE TO OPERATE PROPERLY. CAUTION IS ADVISED WHEN HANDLING PARTS WITH EXPOSED DIAPHRAGM. USE PROTECTIVE CAP WHENEVER DEVICES ARE NOT IN USE.

MODEL SA85BSD-XXXXXX-XXX(XX)

(DCN XXXXX)

Doc No.: OD-SAS85
(Rev.A/ 2023-08-10)

THIRD ANGLE PROJECTION

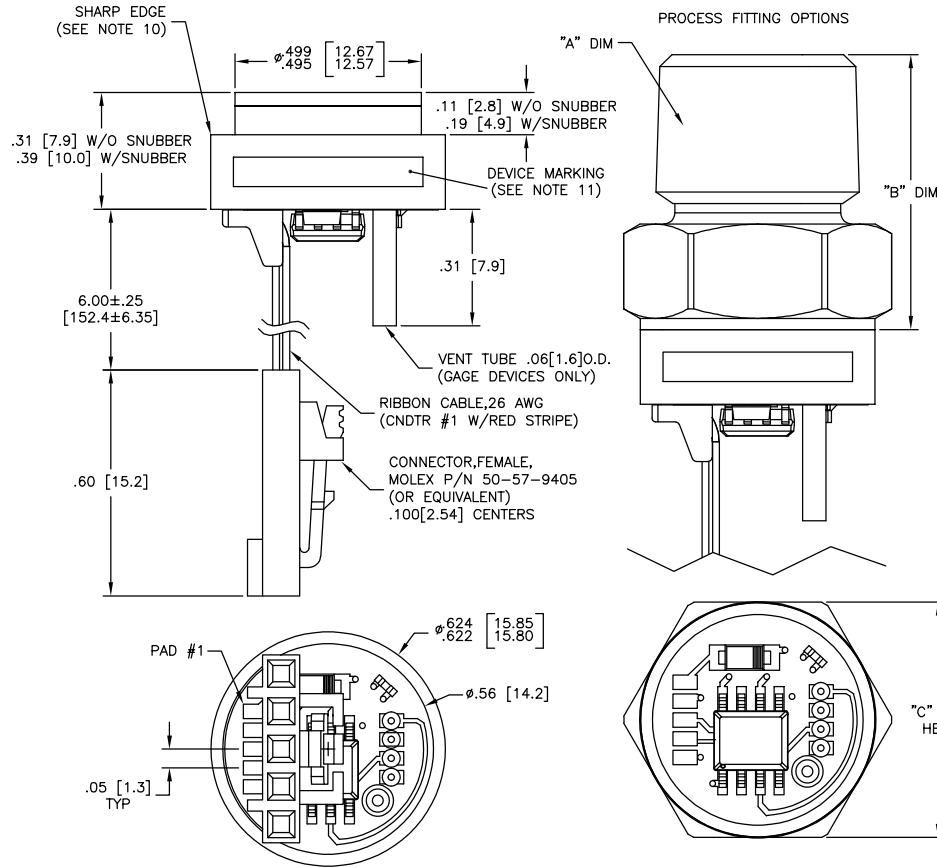
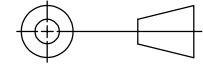

UNLESS OTHERWISE SPECIFIED:
ALL PARAMETERS ARE MEASURED AT 3.3VDC AND AT 25°C

PARAMETERS	MIN	TYP	MAX	UNITS	NOTES
ZERO PRESSURE OUTPUT (10% ~ 90%)	-	666	-	COUNT HEX	1
ZERO PRESSURE OUTPUT (5% ~ 95%)	-	333	-	COUNT HEX	1
FULL SCALE PRESSURE OUTPUT (10% ~ 90%)	-	399A	-	COUNT HEX	1
FULL SCALE PRESSURE OUTPUT (5% ~ 95%)	-	3CCB	-	COUNT HEX	1
PRESSURE ACCURACY	-0.25	-	+0.25	% SPAN	2
TOTAL ERROR BAND	-1	-	+1	% SPAN	3
PRESSURE RESOLUTION	0.008	-	-	% SPAN	
TEMPERATURE ACCURACY	-1.5	-	+1.5	°C	4
TEMPERATURE RESOLUTION	-	0.1	-	°C	
INPUT VOLTAGE RANGE	2.7	3.3	5.5	V	1
SUPPLY CURRENT	-	3	-	mA	
INSULATION RESISTANCE (50 VDC)	50M	-	-	Ω	5
PROOF PRESSURE	-	-	2X	RATED	6
BURST PRESSURE	-	-	3X	RATED	7
LOAD RESISTANCE	10K	-	-	Ω	
LONG TERM STABILITY, (OFFSET&SPAN)	-	±0.5	-	% SPAN/YR	
COMPENSATED TEMPERATURE (≤5PSI)	0	-	+50	°C	
COMPENSATED TEMPERATURE (≥15PSI)	-20	-	+85	°C	
OPERATING TEMPERATURE	-40	-	+125	°C	8
STORAGE TEMPERATURE	-40	-	+125	°C	8
OUTPUT PRESSURE RESOLUTION	-	-	14	BIT	
OUTPUT TEMPERATURE RESOLUTION	8	-	11	BIT	
START TIME TO DATA READY	-	-	8.4	mS	9
OUTPUT TYPE	10% to 90% OR 5% to 95%				
INTERFACE TYPE	I ² C (ADDRESS: 0X28H;0X36H;0X46H); SPI				
MEDIA, PRESSURE PORT	LIQUIDS AND GASES COMPATIBLE WITH 316/316L ST STL				
MEDIA, REFERENCE PORT	LIQUIDS AND GASES COMPATIBLE WITH SILICONE, PYREX, GOLD, FLUOROSILICONE RUBBER AND 316/316L ST STL				

PAD/CNDR	FUNCTION
1	VDD
2	GND
3	SCL/SCLK
4	SDA/MISO
5	INT/SS

DIMENSIONS ARE IN INCHES
TOLERANCES (UNLESS SPECIFIED)
XX=.01
XXX=.005
ANGLES=1/2°

FITTING DIMENSIONS			
FITTING TYPE	"A" DIM	"B" DIM	"C" DIM
1	1/4-18 NPT	.99[25.1]	7/8[22.2]
2	1/8-27 NPT	.96[24.4]	7/8[22.2]
3	7/16-20 UNF	.81[20.6]	7/8[22.2]
4	1/4-18 NPT	.93[23.6]	5/8[15.9]
5	1/4-19 BSP	.96[24.4]	3/4[19.0]
6	1/8-27 NPT	.80[20.3]	5/8[15.9]
7	1/4-19 BSP	.94[23.9]	7/8[22.2]

NOTE: FTG TYPE "4" ASSEMBLY SHOWN
ALL DIMS FOR REFERENCE

ORDERING INFORMATION: SA85BSD-XXXX X X X - X X X X (XX)

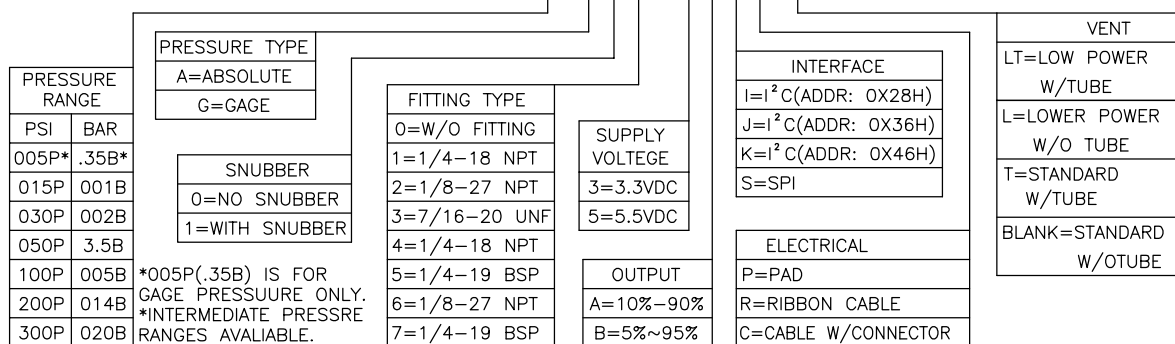

NOTES:

1. MEASURED AT VACUUM FOR ABSOLUTE (A), AMBIENT FOR GAGE (G).OUTPUT IS NOT RATIONMETRIC TO SUPPLY VOLTAGE.
2. ACCURACY : COMBINED LINEARITY,HYSTERESIS AND REPEATILITY.
3. TOTAL BAND: INCLUDES CALIBRATION ERRORS AND TEMPERATURE EFFECTS OVER THE COMPENSATED RANGE. SEE FIG 2 OF SHEET 8.
4. THE DEVIATION FROM A BEST FIT FIT STRAIGHT LINE(BFSL) FITTED TO THE OUTPUT MEASURED OVER THE COMPENSATED TEMPERAURE RAGE. FOR ERRORS BEYOND THE COMPENSATED TEMPERATURE RANGE, SEE FIG 1 OF SHEET 8.
5. BETWEEN CASE AND SENSING ELEMENT.
6. 2X OR 400PSI, WHICHEVER IS LESS, THE MAX PRESSURE THAT CAB BE APPLIED TO A TRANSDUCER WITHOUT CHANGING THE TRANSDUCER'S PERFORMANCE OF ACCURACY.
7. 3X OR 600PSI, WHICHEVER IS LESS, THE MAX PRESSURE THAT CAB BE APPLIED TO A TRANSDUCER WITHOUT RUPTURE OF EITHER THE SENSING ELEMENT OR TRANSDUCER.
8. MAXIMUM TEMPERATURE RANGE FOR PRODUCT WITH STANDARD CABLE AND CONNECTOR IS -20°C TO +105°C.
9. START TIME TO DATA RADY IS THE TIME TO GET VALID DATA AFTER POR (POWER ON RESET). THE TIME TO GET SUBSEQUENT VALID DATA IS THEN SPECIFIED BY THE RESPONSE TIME SPECIFICATION.
10. SHARP EDGE STRONGLY RECOMMENDED FOR WELDING APPLICATION. OPTIUM WELD PARAMETERS WILL REDUCE THE EFFECT OF WELD HEAT ON SENSOR PERFORMANCE. DEVICES WITH LOWER PRESSURE RANGES HAVE GREATER SUSCEPTIBILITY TO HEAT GENERATED DURING THE WELD PROCESS.
11. DEVICE MARKING:
EACH PART SHALL BE IDENTIFIED WITH MODEL NUMBER, PRESSURE RANGE, TYPE (GAGE OR ABSOLUTE), LOT NUMBER, SERIAL NUMBER AND DATE CODE.
12. SHIPPING/PACKAGING REQUIREMENTS:
THE STAINLESS STEEL DIAPHRAGM IS PROTECTED BY A PLASTIC CAP. EACH UNIT WILL BE PACKAGED INDIVIDUALLY IN A PLASTIC VIAL WITH ANTI-STATIC FOAM.
13. DIRECT MECHANICAL CONTACT WITH DIAPHRAGM IS PROHIBITED, DIAPHRAGM SURFACE MUST REMAIN FREE OF DEFECTS (SCRATCHES, PUNCTURES, DENTS,FINGERPRINTS,ECT) FOR DEVICE TO OPERATE PROPERLY. CAUTION IS ADVISED WHEN HANDLING PARTS WITH EXPOSED DIAPHRAGM. USE PROTECTIVE CAP WHENEVER DEVICES ARE NOT IN USE.

BLOCK DIAGRAM

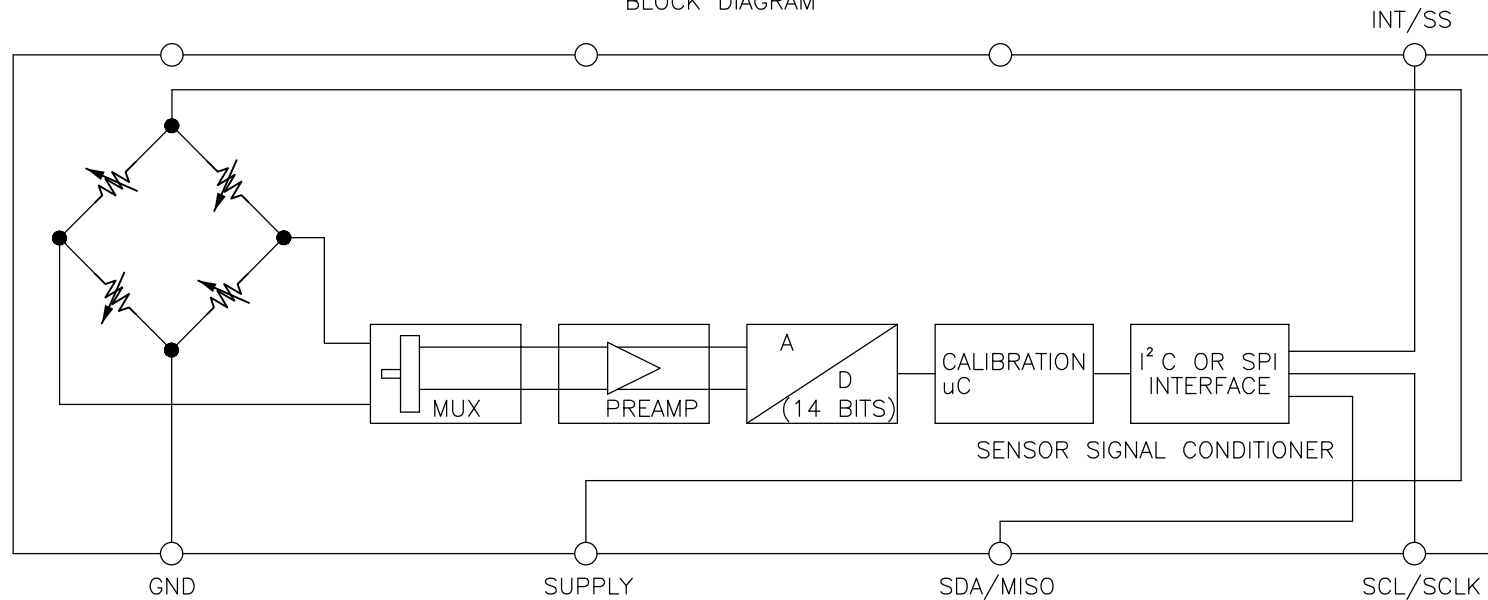

I²C INTERFACE PARAMETERS

PARAMETERS	SYMBOL	MIN	TYPE	MAX	UNITS
SCLK CLOCK FREQUENCY	FSCL	100		400	KHz
START CONDITION HOLD TIME RELATIVE TO SCL EDGE	tHDSTA	0.1			µs
MINIMUM SCL CLOACK LOW WIDTH @1	tLOW	0.6			µs
MINIMUM SCL CLOACK HIGH WIDTH @1	tHIGH	0.6			µs
START CONDITION SETUP TIME RELATIVE TO SCL EDGE	tSUSTA	0.1			µs
DATA HOLD TIME ON SDA RELATIVE TO SCL EDGE	tHDDAT	0			µs
DATA SETUP TIME ON SDA RELATIVE TO SCL EDGE	tSUDA	0.1			µs
STOP CONDITION SETUP TIME ON SCL	tSUSTO	0.1			µs
BUS FREE TIME BETWEEN STOP AND START CONDITION	tBUS	2			µs

SPI INTERFACE PARAMETERS

PARAMETERS	SYMBOL	MIN	TYPE	MAX	UNITS
SCLK CLOCK FREQUENCY	FSCL	50		800	KHz
SS DROP TO FIRST CLOCK EDGE	tHDSS	2.5			µs
MINIMUM SCL CLOACK LOW WIDTH @1	tLOW	0.6			µs
MINIMUM SCL CLOACK HIGH WIDTH @1	tHIGH	0.6			µs
CLOCK EDGE TO DATA TRANSITION	tCLKD	0		0.1	µs
RISE OF SS RELATIVE TO LAST CLOCK EDGE	tSUSS	0.1			µs
BUS FREE TIME BETWEEN RISE AND FALL OF SS	tBUS	2			µs

@1 COMBINED LOW AND HIGH WIDTHS MUST EQUAL OR EXCEED MINIMUM SCL PERIOD.

TEMPERATURE ACCURACY AND TOTAL ERROR BAND

FIG 1

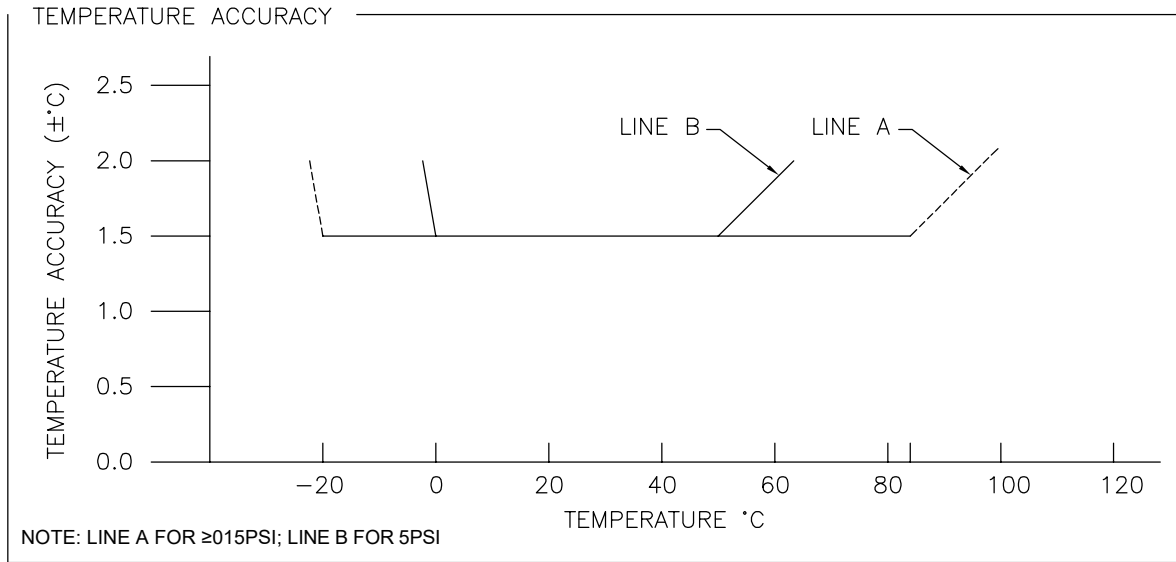
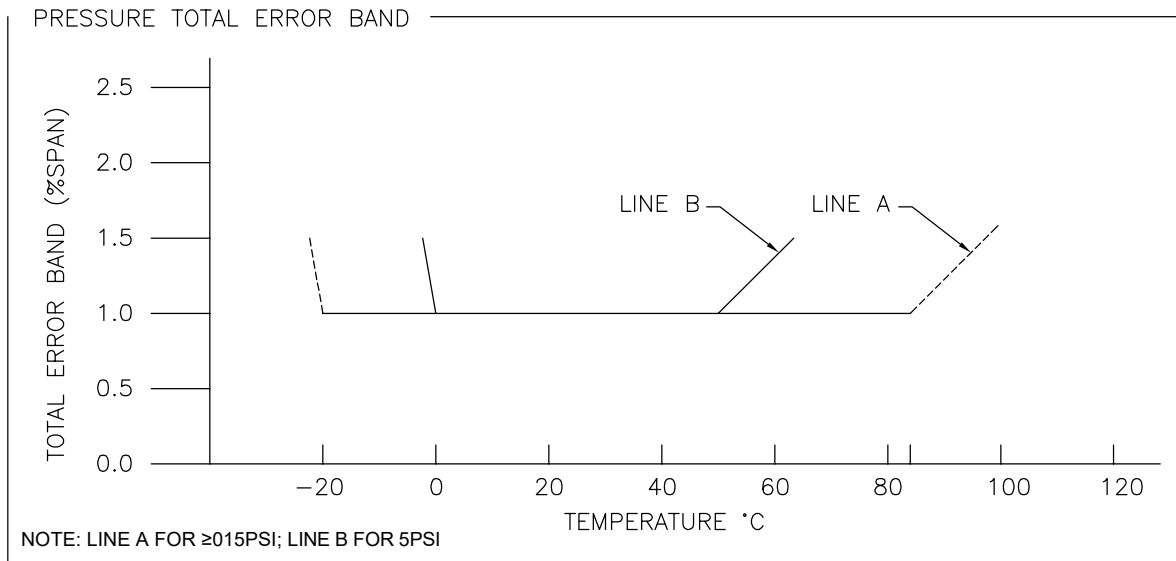
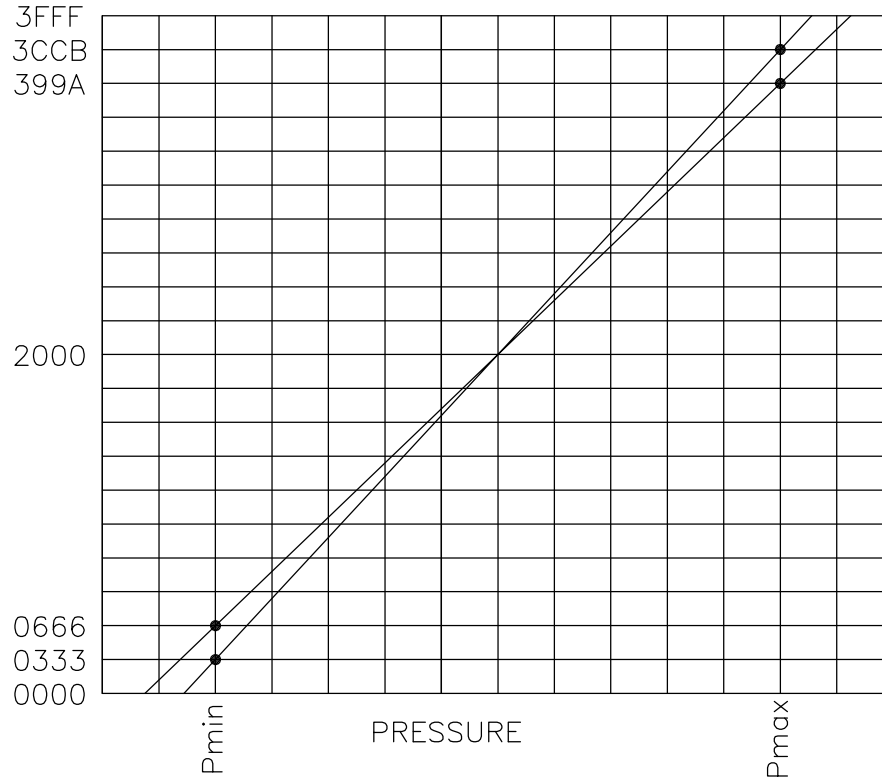

FIG 2



PRESSURE FUNCTION



SENSOR OUPUT AT SIGNIFIANT PERCENTAGES

%OUTPUT	DIGITAL COUNTS (DECIMAL)	DIGITAL COUNTS (HEX)
0	0	0 X 0000
5	819	0 X 0333
10	1638	0 X 0666
50	8192	0 X 2000
90	14746	0 X 399A
95	15563	0 X 3CCB
100	16383	0 X 3FFF

$$A \text{ TYPE: OUT (DECIMAL COUNTS)} = \frac{80\% \cdot 16388}{P_{\max} - P_{\min}} * (P_{\text{applied}} - P_{\min}) + 10\% \cdot 816383$$

$$B \text{ TYPE: OUT (DECIMAL COUNTS)} = \frac{90\% \cdot 16388}{P_{\max} - P_{\min}} * (P_{\text{applied}} - P_{\min}) + 5\% \cdot 816383$$

TEMPERATURE FUNCTION

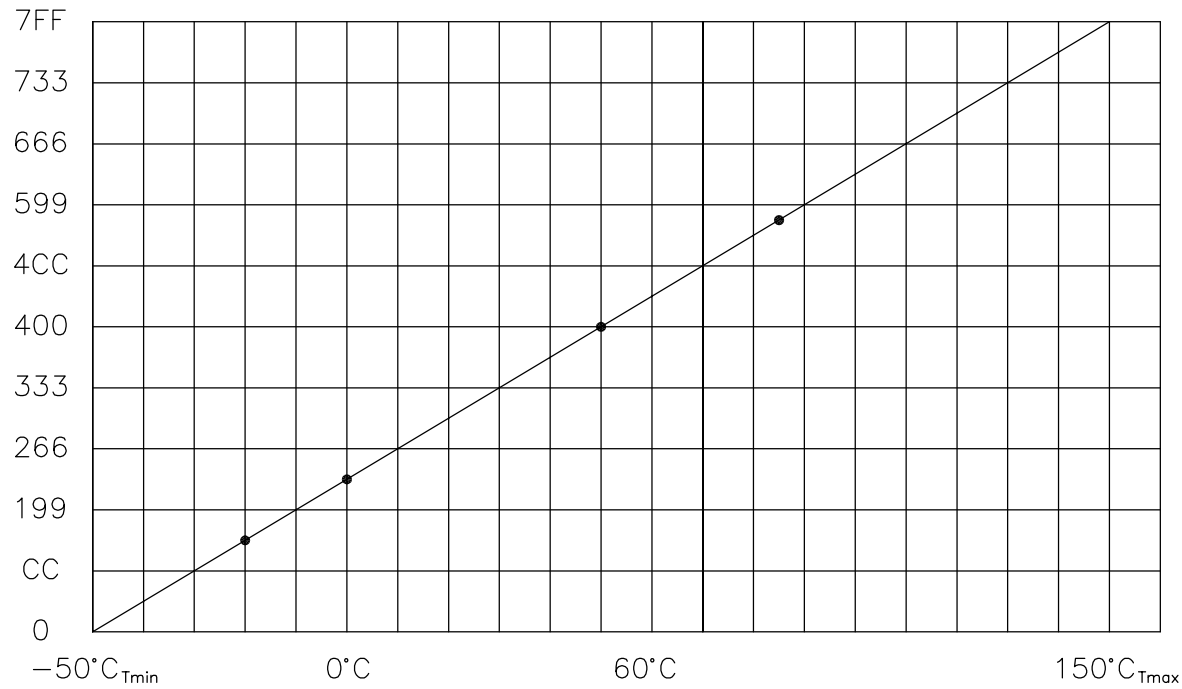

DIGITAL TEMPERATURE OUTPUT

OUTPUT°C	DIGITAL COUNTS (DECIMAL)	DIGITAL COUNTS (HEX)
-50	0	0 X 0000
-20	317	0 X 0133
0	512	0 X 0200
25	767	0 X 02FF
50	1024	0 X 0400
85	1381	0 X 0565
150	2047	0 X 07FF

$$\text{OUT (DECIMAL COUNTS)} = \frac{(\text{OUTPUT}^\circ\text{C} - (-50^\circ\text{C}_{Tmin})) * 2047}{150^\circ\text{C}_{Tmax} - (-50^\circ\text{C}_{Tmin})}$$