

MODEL SAABPCS SERIES

Doc No.: OD-SAABPCS
(Rev.A/ 2023-08-18)
Sh 1 of 15

(DCN XXXXX)

NOMENCLATURE AND ORDER GUIDE

THIRD ANGLE PROJECTION

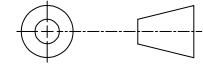

Product Series

ABPC Amplified Basic

SA ABPCS

X

XX

X

XXXXX

X

X

X

Package

D DIP (Dual Inline Pin)

M SMT

L Leadless SMT

Port

DIP

SMT

Leadless SMT

Supply Voltage

3 3.3 Vdc

5 5.0 Vdc

Transfer Function

A 10% to 90% of Vsupply (analog), 2¹⁴ counts (digital)
no temperature output, no sleep mode

D 10% to 90% of 2¹⁴ counts (digital only)
temperature output enabled, sleep mode enabled

S 10% to 90% of 2¹⁴ counts (digital only)
no temperature output, sleep mode enabled

T 10% to 90% of 2¹⁴ counts (digital only)
temperature output enabled, no sleep mode

Output Type

A Analog 3 I²C, Address 0x38

S SPI 4 I²C, Address 0x48

0 I²C, Address 0x08 5 I²C, Address 0x58

1 I²C, Address 0x18 6 I²C, Address 0x68

2 I²C, Address 0x28 7 I²C, Address 0x78

Pressure Range

60 mbar to 10 bar

6 kPa to 1 MPa

1 psi to 150 psi

Differential

060MD ±60 mbar

100MD ±100 mbar

160MD ±160 mbar

250MD ±250 mbar

400MD ±400 mbar

600MD ±600 mbar

001BD ±1 bar

1.6BD ±1.6 bar

2.5BD ±2.5 bar

004BD ±4 bar

Differential

006KD ±6 kPa

010KD ±10 kPa

016KD ±16 kPa

025KD ±25 kPa

040KD ±40 kPa

060KD ±60 kPa

100KD ±100 kPa

160KD ±160 kPa

250KD ±250 kPa

400KD ±400 kPa

Differential

001PD ±1Psi

005PD ±5psi

015PD ±15psi

030PD ±30Psi

060PD ±60Psi

Gage

060MG 0 mbar to 60 mbar

100MG 0 mbar to 100 mbar

160MG 0 mbar to 160 mbar

250MG 0 mbar to 250 mbar

400MG 0 bar to 400 mbar

600MG 0 bar to 600 mbar

001BG 0 bar to 1 bar

1.6BG 0 bar to 1.6 bar

2.5BG 0 bar to 2.5 bar

004BG 0 bar to 4 bar

006BG 0 bar to 6 bar

010BG 0 bar to 10 bar

Gage

006KG 0 kPa to 6 kPa

010KG 0 kPa to 10 kPa

016KG 0 kPa to 16 kPa

025KG 0 kPa to 25 kPa

040KG 0 kPa to 40 kPa

060KG 0 kPa to 60 kPa

100KG 0 kPa to 100 kPa

160KG 0 kPa to 160 kPa

250KG 0 kPa to 250 kPa

400KG 0 kPa to 400 kPa

600KG 0 kPa to 600 kPa

001GG 0 kPa to 1 MPa

Gage

001PG 0Psi to 1Psi

005PG 0Psi to 5Psi

015PG 0Psi to 15Psi

030PG 0Psi to 30Psi

060PG 0Psi to 60Psi

100PG 0Psi to 100Psi

150PG 0Psi to 150Psi

No port

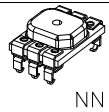
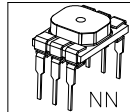

Single axial barbless port

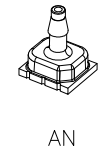
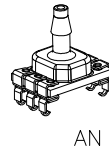
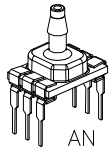

Single axial barbless port

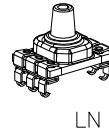
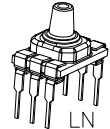

Single radial barbless port

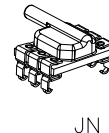
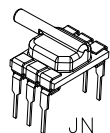

Dual radial barbless port same side

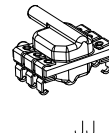
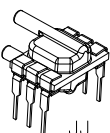

Single radial barbed port

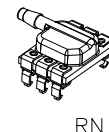
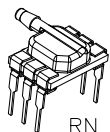

Dual radial barbed port same side

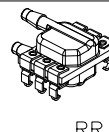
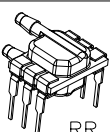

*FIGURE 1

OPTION

N Dry gases only, no diagnostics

D Dry gases only, diagnostics on

T Liquid media, silicone gel, no diagnostics

V Liquid media, silicone gel, diagnostics on

F Liquid media, flourosilicone gel, diagnostics on

F Liquid media, flourosilicone gel, no diagnostics

MODEL SAABPCS SERIES

Doc No.: OD-SAABPCS
(Rev.A/ 2023-08-18)
Sh 2 of 15

(DCN XXXXX)

THIRD ANGLE PROJECTION

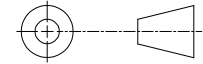

OPERATING SPECIFICATIONS

TABLE 1. *ABSOLUTE MAXIMUM RATINGS

CHARACTERISTIC	MIN	MAX	UNITS
Supply voltage (Vsupply)	-0.3	6.0	Vdc
Voltage on any pin	-0.3	Vsupply+0.3	V
Digital interface			
clock frequency:	I ² C	100	400
	SPI	50	800
ESD susceptibility (human body model)	2	-	kV
Storage temperature	-40[-40]	85[185]	°C[°F]
Soldering time and temperature:			
lead solder temperature (DIP)	4 s max. at 250°C [482°F]		
peak reflow temperature (Leadless SMT, SMT)	15 s max. at 250°C [482°F]		

*Absolute maximum ratings are the extreme limits the device will withstand without damage.

TABLE 2. ENVIRONMENTAL SPECIFICATIONS

CHARACTERISTIC	PARAMETERS
Humidity:	
all external surfaces	0 %RH to 95 %RH, non-condensing
internal surfaces of Liquid Media Option (T, V, F, G)	0 %RH to 100 %RH, condensing
internal surfaces of Dry Gases Option (N, D)	0 %RH to 95 %RH, non-condensing
Vibration	15 g, 10 Hz to 2 kHz
Shock	100 g, 6 ms duration
*Life	1 million pressure cycles minimum
Solder reflow	J-STD-020-D.1 Moisture Sensitivity Level 1 (unlimited shelf life when stored at <30°C/85 %RH)

*Life may vary depending on specific application in which the sensor is used.

TABLE 3. *WETTED MATERIALS

COMPONENT	PRESSURE PORT 1 (P1)		PRESSURE PORT 2 (P2)
	DRY GAS OPTION	LIQUID MEDIA OPTION	
Ports and covers	high temperature polyamide		
Substrate	alumina ceramic	-	alumina ceramic
Adhesives	epoxy, silicone	epoxy, silicone gel	epoxy, silicone
Electronic components	silicon, glass, solder gold,alumina	304 SST	silicon

*Contact SQMEAS Customer Service for detailed material information.

TABLE 4. SENSOR PRESSURE TYPES

PRESSURE TYPE	DESCRIPTION
Gage	Output is proportional to the difference between applied pressure and atmospheric (ambient) pressure.
Differential	Output is proportional to the difference between the pressures applied to each port (Port 1 - Port 2).

MODEL SAABPCS SERIES

Doc No.: OD-SAABPCS
(Rev.A/ 2023-08-18)
Sh 3 of 15

(DCN XXXXX)

THIRD ANGLE PROJECTION

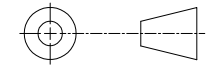

OPERATING SPECIFICATIONS

TABLE 5. OPERATING SPECIFICATIONS

CHARACTERISTIC		ANALOG			DIGITAL			UNITS	NOTES
		MIN	TYP	MAX	MIN	TYP	MAX		
Supply voltage	3.3 Vdc	3.0	3.3	3.6	3.0	3.3	3.6	Vdc	1,2,3
	5.0 Vdc	4.75	5.0	5.25	4.75	5.0	5.25		
Supply current	3.3 Vdc	–	2.1	2.8	–	3.1	3.9	mA	
	5.0 Vdc	–	2.7	3.8	–	3.7	4.6	mA	
	sleep mode option	–	–	–	–	1	10	uA	
Operating temperature range		–40	–	+85	–40	–	85	°C	4
Compensated temperature range		0	–	50	0	–	50	°C	5
Temperature output option		–	–	–	–	±4	–	°C	6
Startup time (power up to data ready)		–	–	5	–	–	3	mS	
Response time		–	1	–	–	0.46	–	mS	
Clipping limit	upper	–	–	97.5	–	–	–	%Vsupply	
	lower	2.5	–	–	–	–	–		
I ² C/SPI voltage level	low	–	–	–	–	–	20	%Vsupply	
	high	–	–	–	80	–	–		
Pull up on SDA/MISO, SCL/SCLK, SS		–	–	–	1	–	–	kOhm	
Total Error Band		–	–	±1.5	–	–	±1.5	%FSS	7,8
Accuracy		–	–	±0.25	–	–	±0.25	%FSS BFSL	9
Long term stability (1000 hr, 25°C)		–	–	±0.25	–	–	±0.25	%FSS	
Output resolution		0.3	–	–	–	–	–	%FSS	
		–	–	–	12	–	–	bits	

Notes:

- Sensors are either 3.3 Vdc or 5.0 Vdc based on the catalog listing selected.
- Ratiometricity of the sensor (the ability of the device output to scale to the supply voltage) is achieved within the specified rating voltage.
- The sensor is not reverse polarity protected. Incorrect application of supply voltage or ground to the wrong pin may cause electrical failure.
- Operating temperature range: The temperature range over which the sensor will produce an output proportional to pressure.
- Compensated temperature range: The temperature range over which the sensor will produce an output proportional to pressure within the specified performance limits.
- Temperature output option: Typical temperature output error over the compensated temperature range of 0°C to 50°C. Operation in Sleep Mode may affect temperature output error depending on duty cycle.
- Total Error Band: The maximum deviation from the ideal transfer function over the entire compensated temperature and pressure range. Includes all errors due to offset, full scale span, pressure non-linearity, pressure hysteresis, repeatability, thermal effect on offset, thermal effect on span, and thermal hysteresis.
- Full Scale Span (FSS): The algebraic difference between the output signal measured at the maximum (Pmax.) and minimum (Pmin.) limits of the pressure range. (See Figure 1.)
- Accuracy: The maximum deviation in output from a Best Fit Straight Line (BFSL) fitted to the output measured over the pressure range at 25°C [77°F]. Includes all errors due to pressure non-linearity, pressure hysteresis, and non-repeatability.

TABLE 6. SENSOR OUTPUT AT SIGNIFICANT PERCENTAGES (DIGITAL VERSIONS ONLY)

% OUTPUT	DIGITAL COUNTS	
	DECIMAL	HEX
0	0	0X0000
10	1638	0X0666
50	8192	0X2000
90	14746	0X399A
100	16383	0X3FFF

FIGURE 1. PRESSURE FUNCTION

Analog Versions

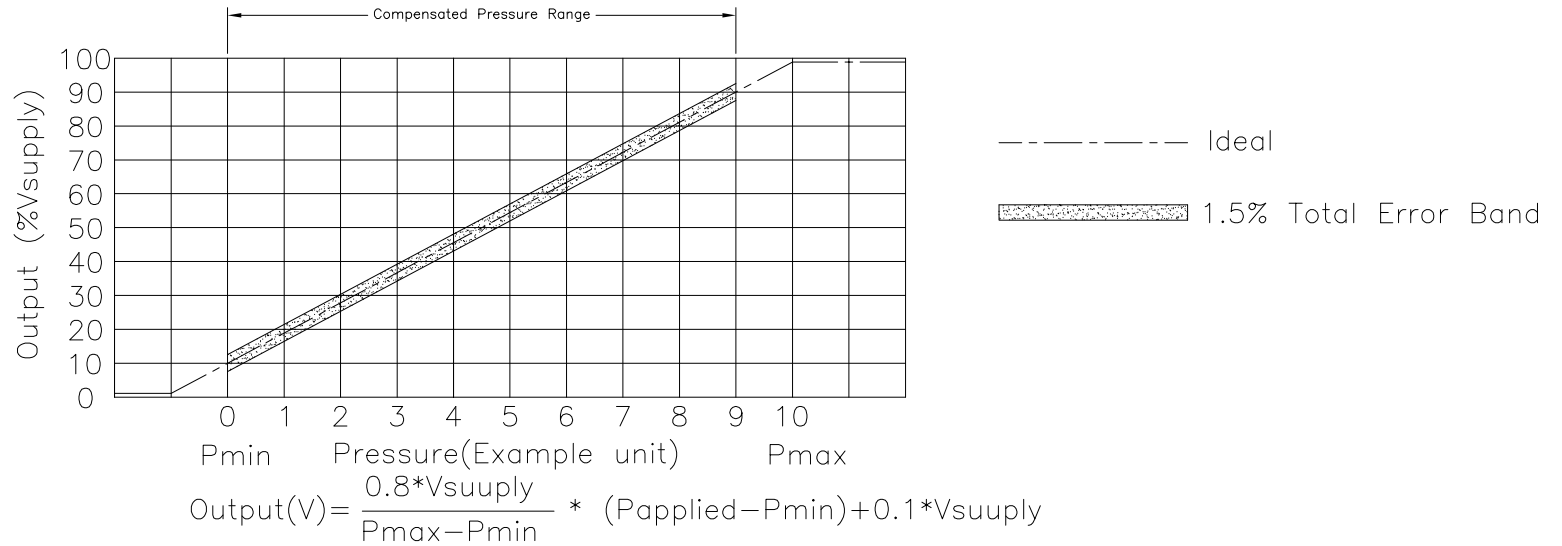

Digital Versions

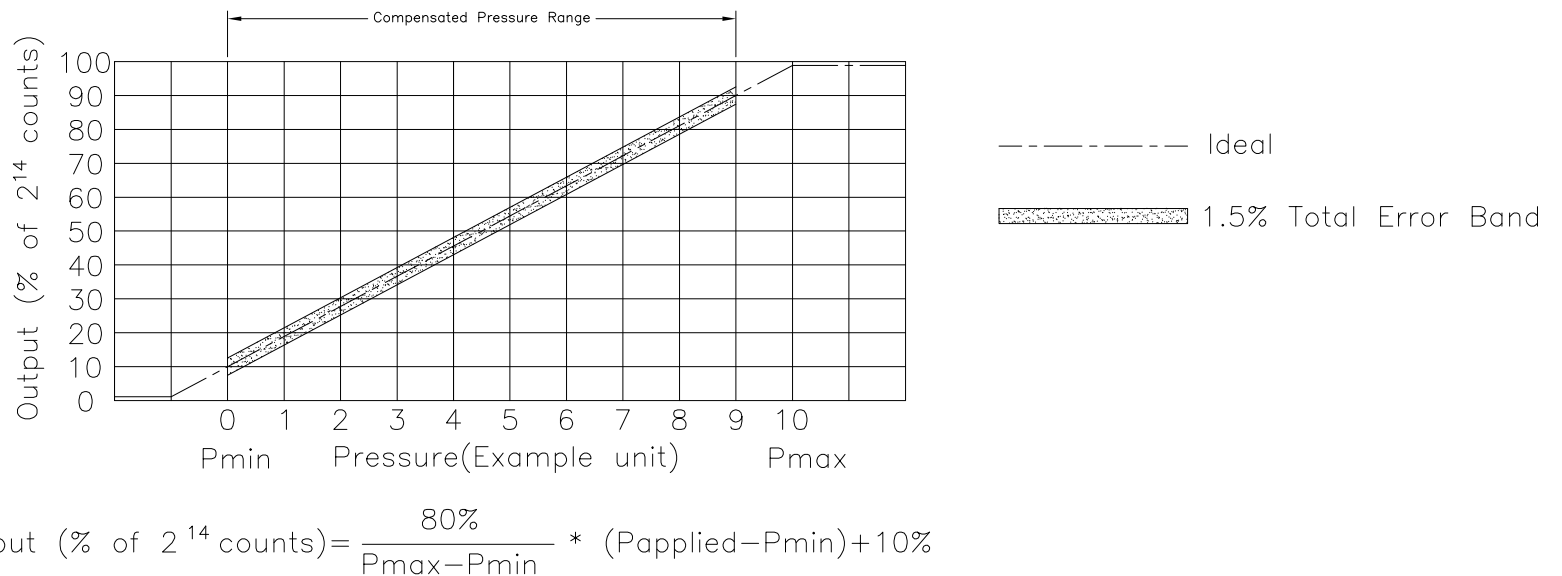

MODEL SAABPCS SERIES

Doc No.: OD-SAABPCS
(Rev.A/ 2023-08-18)
Sh 5 of 15

(DCN XXXXX)

THIRD ANGLE PROJECTION

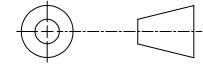

PRESSURE RANGE SPECIFICATIONS

RANGE (SEE FIGURE1.)	PRESSURE RANGE			OVERPRESSURE		BURST PRESSURE		COMMON MODE PRESSURE
	PMIN.	PMAX.	UNIT	Port 1 (P1)	Port 2 (P2)	Port 1 (P1)	Port 2 (P2)	
60 mbar to 10 bar (Differential)								
060MD	-60	60	mbar	2000	850	3500	1000	10000
100MD	-100	100	mbar	4000	1400	7000	2500	10000
160MD	-160	160	mbar	4000	1400	7000	2500	10000
250MD	-250	250	mbar	10000	2000	19000	4000	10000
400MD	-400	400	mbar	10000	2000	19000	4000	10000
600MD	-600	6	mbar	17000	2000	19000	4000	10000
001BD	-1	1	bar	17	4	19	8	17
1.6BD	-1.6	1.6	bar	17	8	19	16	17
2.5BD	-2.5	2.5	bar	17	8	19	16	17
004BD	-4.0	4.0	bar	17	16	19	19	17
60 mbar to 10 bar (Gage)								
060MG	0	60	mbar	2000	-	3500	-	5500
100MG	0	100	mbar	2000	-	3500	-	10000
160MG	0	160	mbar	2000	-	3500	-	10000
250MG	0	250	mbar	4000	-	7000	-	10000
400MG	0	400	mbar	10000	-	19000	-	10000
600MG	0	600	mbar	10000	-	19000	-	10000
001BG	0	1	bar	17	-	19	-	17
1.6BG	0	1.6	bar	17	-	19	-	17
2.5BG	0	2.5	bar	17	-	19	-	17
004BG	0	4	bar	17	-	19	-	17
006BG	0	6	bar	17	-	19	-	17
010BG	0	10	bar	17	-	19	-	17
6 kPa to 1 MPa (Differential)								
006KD	-6	6	kPa	200	85	350	100	1000
010KD	-10	10	kPa	400	140	700	250	1000
016KD	-16	16	kPa	400	140	700	250	1000
025KD	-25	25	kPa	1000	200	1900	400	1000
040KD	-40	40	kPa	1000	200	1900	400	1000
060KD	-60	60	kPa	1700	200	1900	400	1000
100KD	-100	100	kPa	1700	400	1900	800	1700
160KD	-160	160	kPa	1700	800	1900	1600	1700
250KD	-250	250	kPa	1700	800	1900	1600	1700
400KD	-400	400	kPa	1700	1600	1900	1900	1700

TO BE CONTINUED

MODEL SAABPCS SERIES

Doc No.: OD-SAABPCS
(Rev.A/ 2023-08-18)
Sh 6 of 15

(DCN XXXXX)

THIRD ANGLE PROJECTION

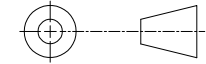

PRESSURE RANGE SPECIFICATIONS (CONTINUED)

RANGE (SEE FIGURE 1.)	PRESSURE RANGE			OVERPRESSURE		BURST PRESSURE		COMMON MODE PRESSURE
	PMIN.	P MAX.	UNIT	Port 1 (P1)	Port 2 (P2)	Port 1 (P1)	Port 2 (P2)	
6 kPa to 1 MPa (Gage)								
006KG	0	6	kPa	200	–	350	–	550
010KG	0	10	kPa	200	–	350	–	1000
016KG	0	16	kPa	200	–	350	–	1000
025KG	0	25	kPa	400	–	700	–	1000
040KG	0	40	kPa	1000	–	1900	–	1000
060KG	0	60	kPa	1000	–	1900	–	1000
100KG	0	100	kPa	1700	–	1900	–	1700
160KG	0	160	kPa	1700	–	1900	–	1700
250KG	0	250	kPa	1700	–	1900	–	1700
400KG	0	400	kPa	1700	–	1900	–	1700
600KG	0	600	kPa	1700	–	1900	–	1700
001GG	0	1	MPa	1.7	–	1.9	–	1.7
1 psi to 150 psi(Differential)								
001PD	–1	1	psi	30	10	50	15	150
005PD	–5	5	psi	150	30	275	40	150
015PD	–15	15	psi	250	60	275	120	250
030PD	–30	30	psi	250	120	275	240	250
060PD	–60	60	psi	250	250	275	275	250
1 psi to 150 psi(Gage)								
001PG	0	1	psi	30	–	50	–	150
005PG	0	5	psi	150	–	275	–	150
015PG	0	15	psi	250	–	275	–	250
030PG	0	30	psi	250	–	275	–	250
060PG	0	60	psi	250	–	275	–	250
100PG	0	100	psi	250	–	275	–	250
150PG	0	150	psi	250	–	275	–	250

1. Overpressure: The maximum pressure which may safely be applied to the product for it to remain in specification once pressure is returned to the operating pressure range. Exposure to higher pressures may cause permanent damage to the product. Unless otherwise specified this applies to all available pressure ports at any temperature with the operating temperature range.
2. Burst pressure: The maximum pressure that may be applied to the specified port (P1 or P2) of the product without causing escape of pressure media. Product should not be expected to function after exposure to any pressure beyond the burst pressure.
3. Common mode pressure: The maximum pressure that can be applied simultaneously to both ports of a differential pressure sensor without causing changes in specified performance.

MODEL SAABPCS SERIES

Doc No.: OD-SAABPCS
(Rev.A/ 2023-08-18)
Sh 7 of 15

(DCN XXXXX)

THIRD ANGLE PROJECTION

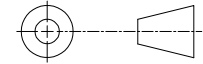

PACKAGE DIMENSIONAL DRAWINGS

DIP NN

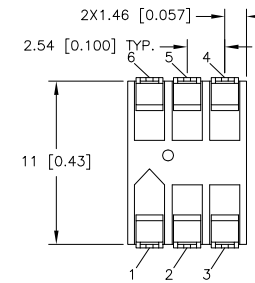
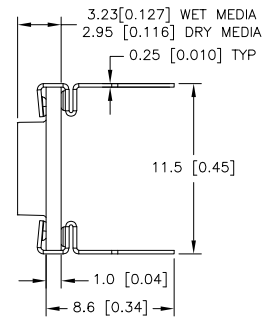
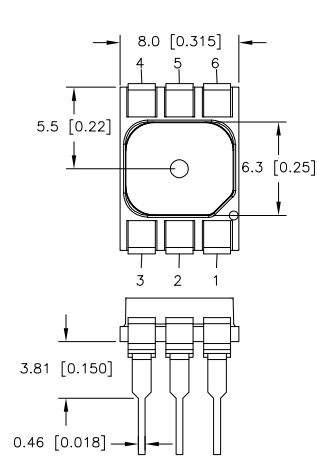
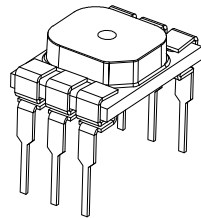

DIP AN

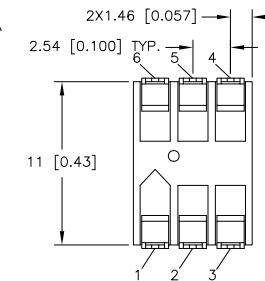
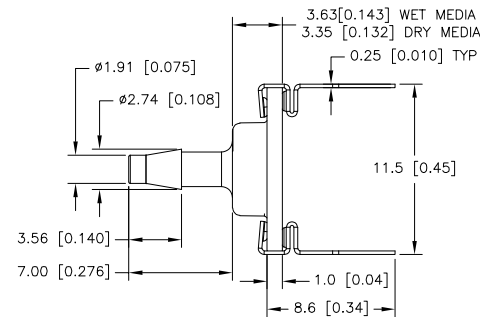
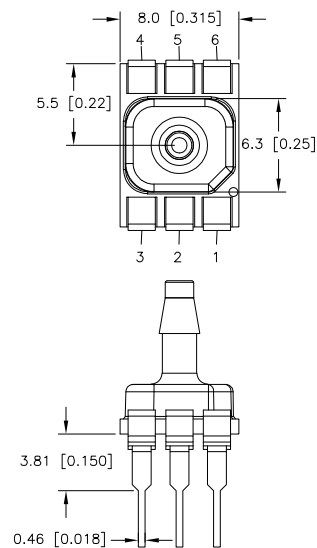
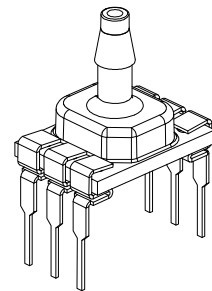

[DIMENSIONS] ARE IN INCHES

TOLERANCES (UNLESS SPECIFIED)

.XX=.01
.XXX=.005
ANGLES=1/2°

MODEL SAABPCS SERIES

Doc No.: OD-SAABPCS
(Rev.A/ 2023-08-18)
Sh 8 of 15

(DCN XXXXX)

THIRD ANGLE PROJECTION

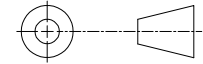

PACKAGE DIMENSIONAL DRAWINGS

DIP LN

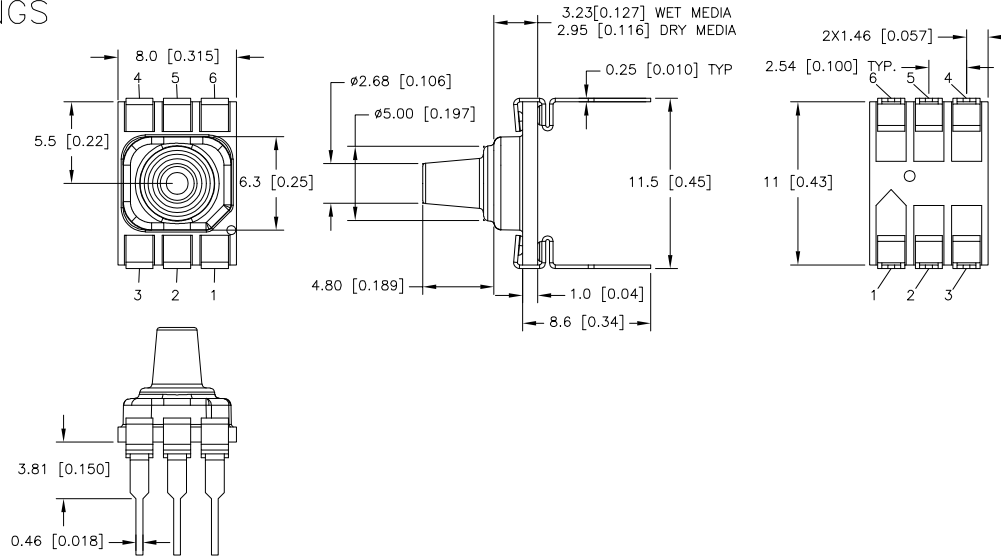
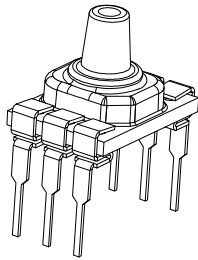

DIP JN

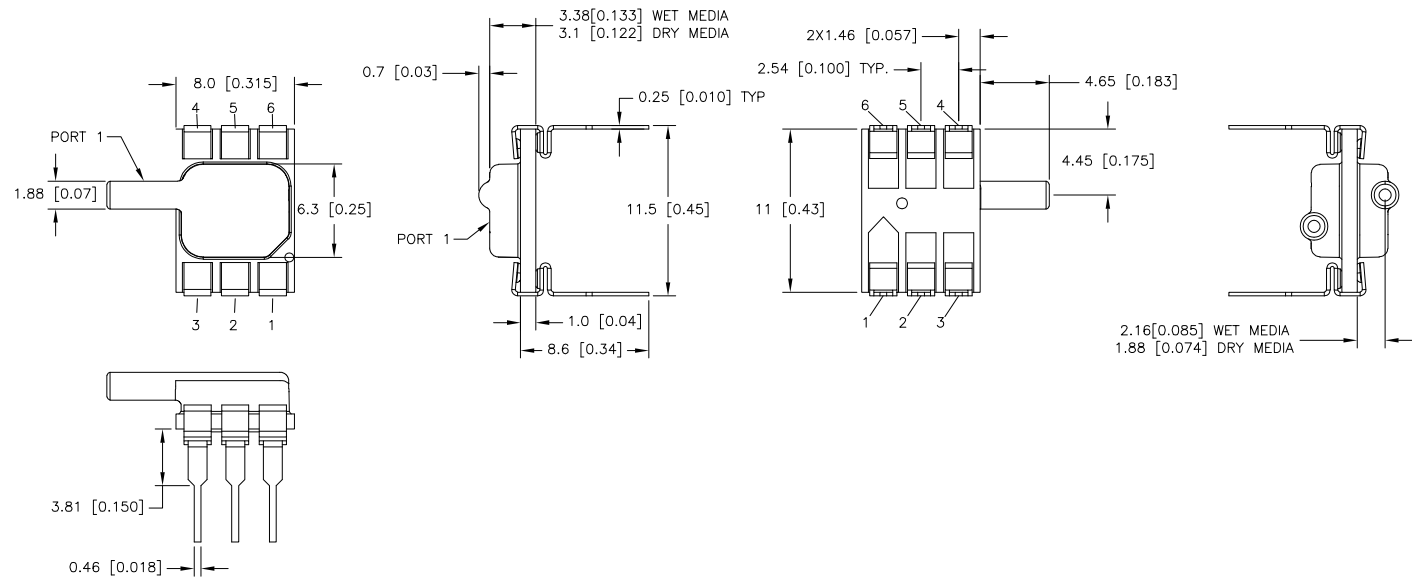
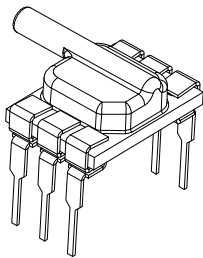

[DIMENSIONS] ARE IN INCHES

TOLERANCES (UNLESS SPECIFIED)

.XX=.01
.XXX=.005
ANGLES=1/2°

MODEL SAABPCS SERIES

Doc No.: OD-SAABPCS
(Rev.A/ 2023-08-18)
Sh 9 of 15

(DCN XXXXX)

THIRD ANGLE PROJECTION

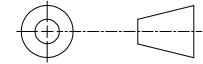

PACKAGE DIMENSIONAL DRAWINGS

DIP JU

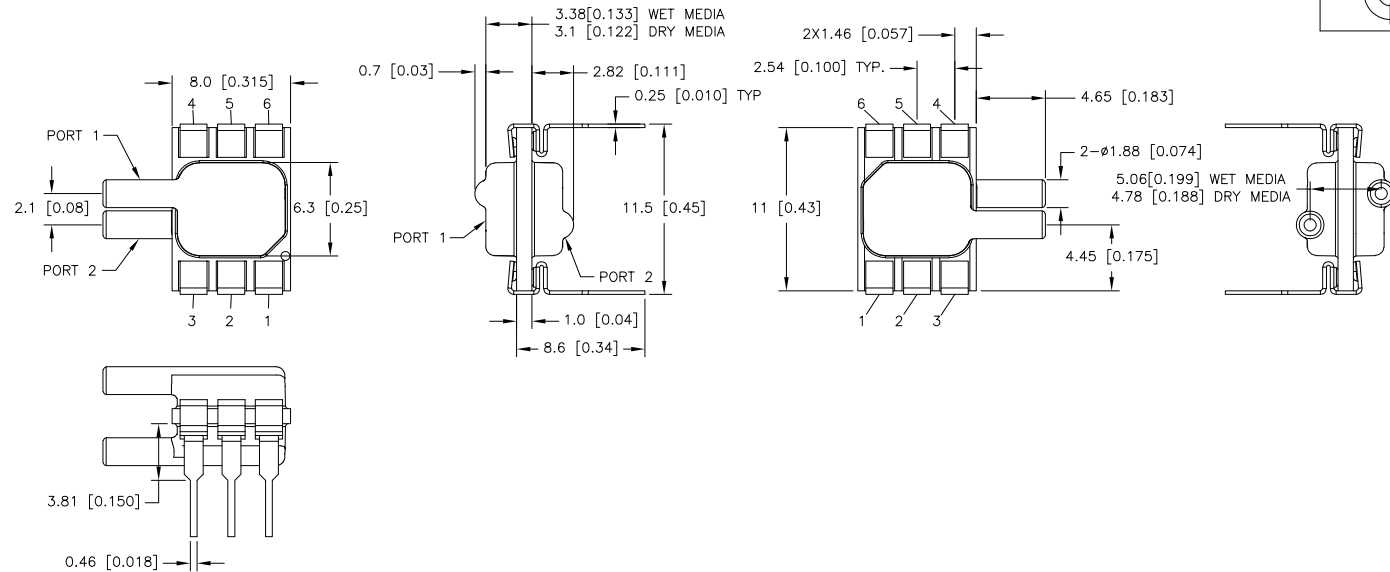
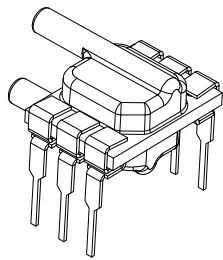

DIP RN

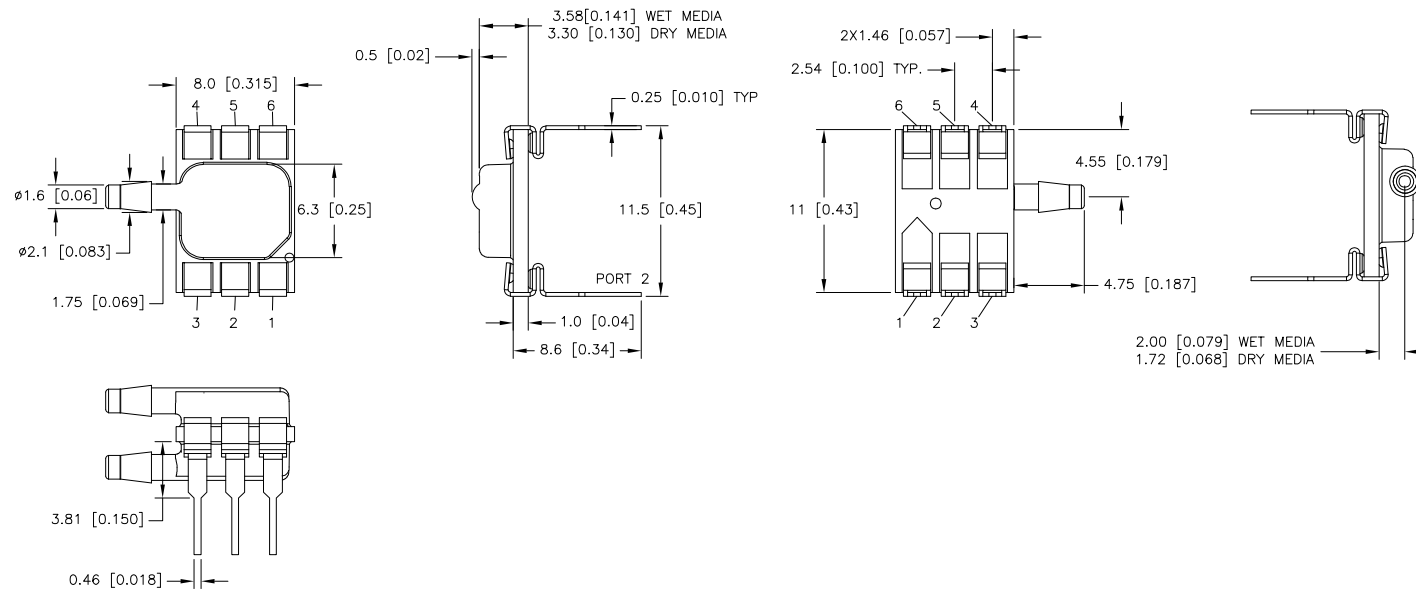
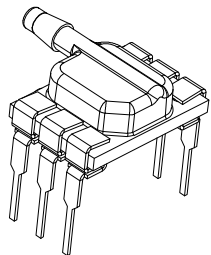

[DIMENSIONS] ARE IN INCHES

TOLERANCES (UNLESS SPECIFIED)

.XX=.01
.XXX=.005
ANGLES=1/2°

MODEL SAABPCS SERIES

Doc No.: OD-SAABPCS
(Rev.A/ 2023-08-18)
Sh 10 of 15

(DCN XXXXX)

THIRD ANGLE PROJECTION

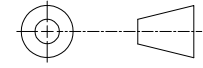

DIP RR

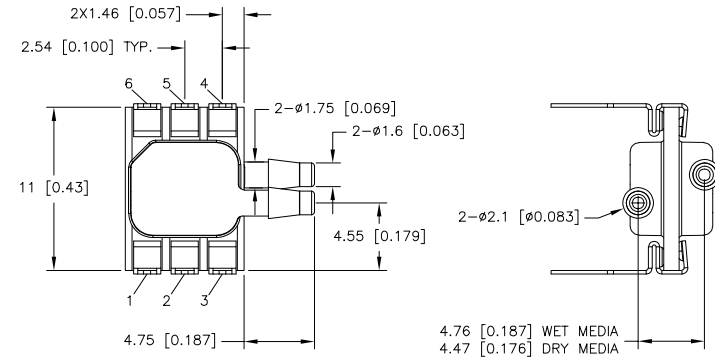
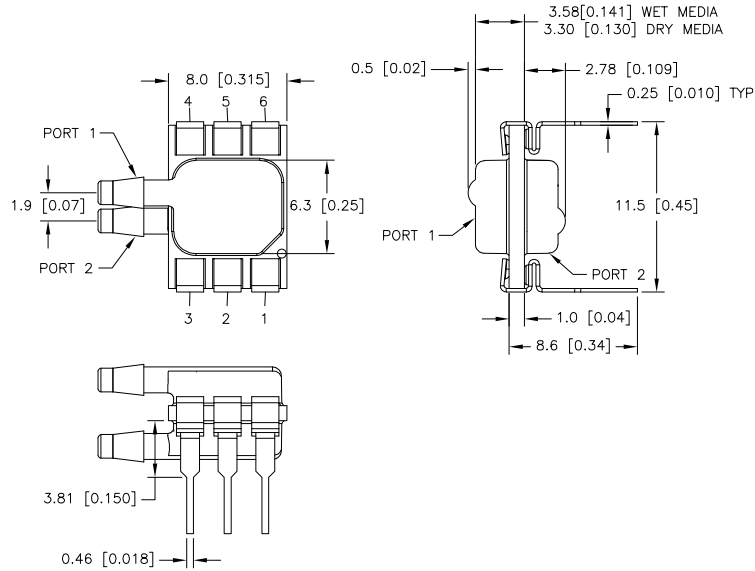
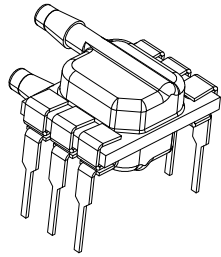

SMT NN

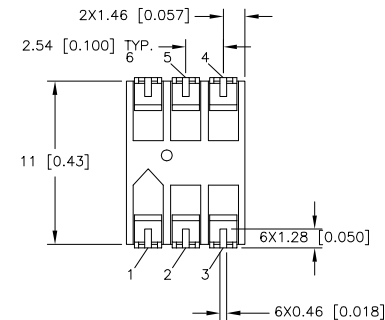
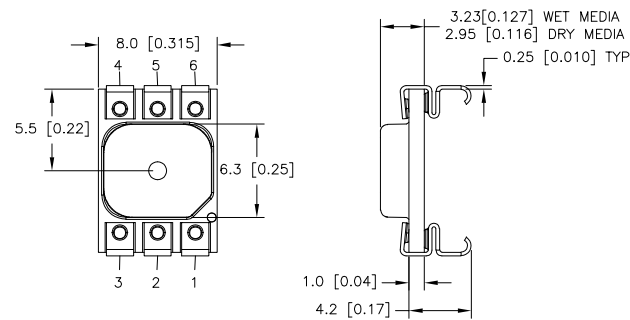
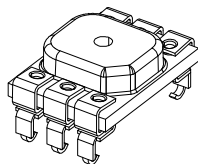

[DIMENSIONS] ARE IN INCHES

TOLERANCES (UNLESS SPECIFIED)

.XX=.01
.XXX=.005
ANGLES=1/2°

CONFIDENTIAL: THIS DRAWING AND THE INFORMATION CONTAINED HEREIN IS THE PROPERTY OF SENSORALL Co, LTD, AND SHALL NOT BE USED, REPRODUCED, PUBLISHED, OR DISCLOSED TO OTHERS WITHOUT THE EXPRESS WRITTEN CONSENT OF SENSORALL Co, LTD. ALL DATA SUBJECT TO CHANGE. CONSULT FACTORY FOR DETAILS.

MODEL SAABPCS SERIES

Doc No.: OD-SAABPCS
(Rev.A/ 2023-08-18)
Sh 13 of 15

(DCN XXXXX)

THIRD ANGLE PROJECTION

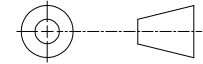

PACKAGE DIMENSIONAL DRAWINGS

SMT RN

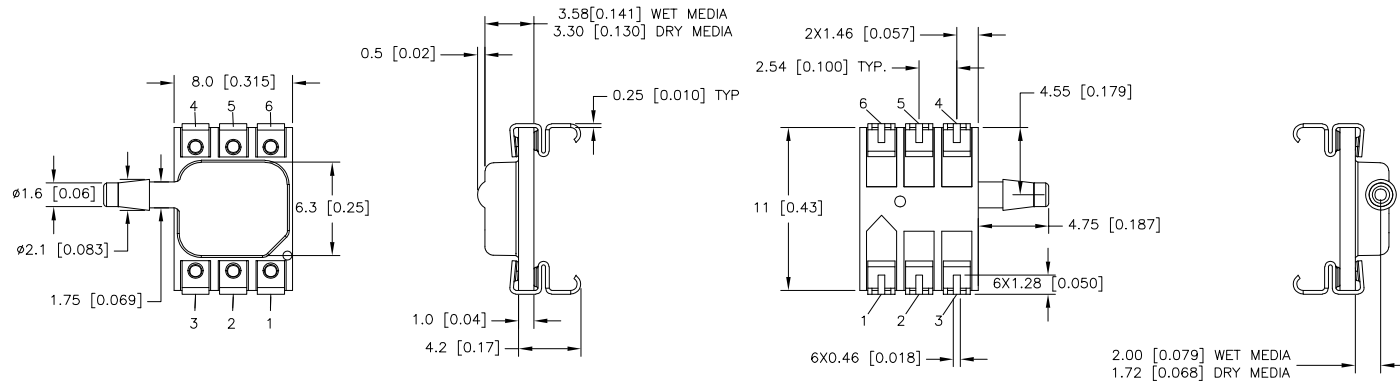
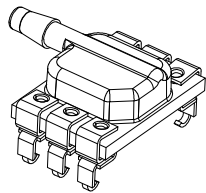

SMT RR

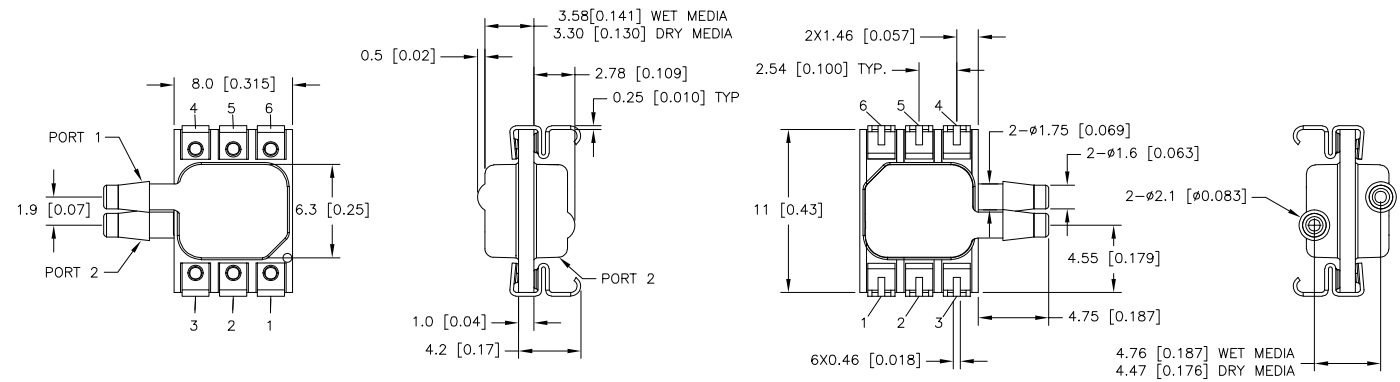
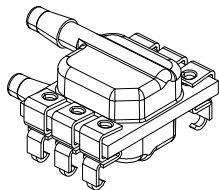

[DIMENSIONS] ARE IN INCHES

TOLERANCES (UNLESS SPECIFIED)

.XX=.01
.XXX=.005
ANGLES=1/2°

MODEL SAABPCS SERIES

Doc No.: OD-SAABPCS
(Rev.A/ 2023-08-18)
Sh 14 of 15

(DCN XXXXX)

THIRD ANGLE PROJECTION

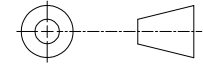

PACKAGE DIMENSIONAL DRAWINGS

Leadless SMT NN

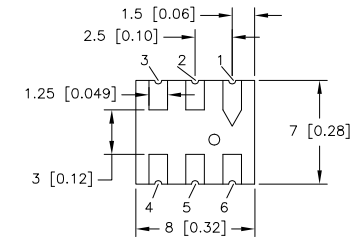
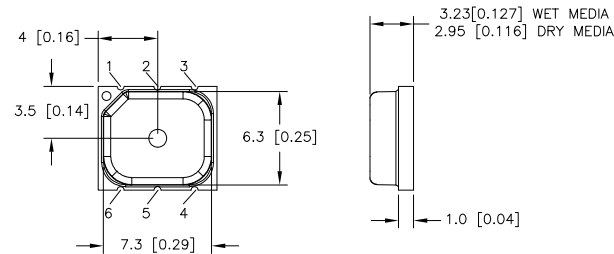
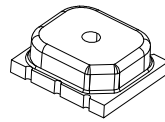

Leadless SMT AN

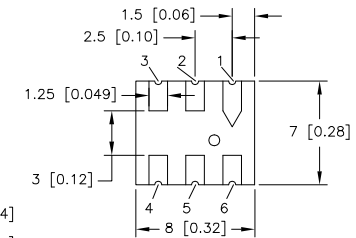
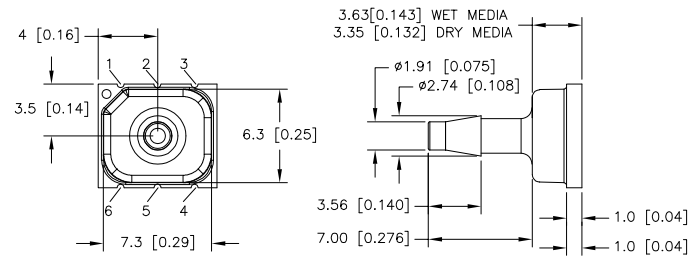
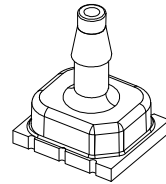

Leadless SMT LN

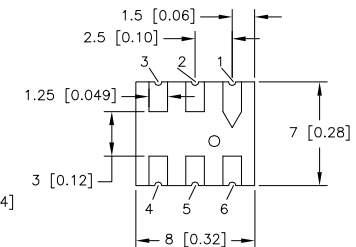
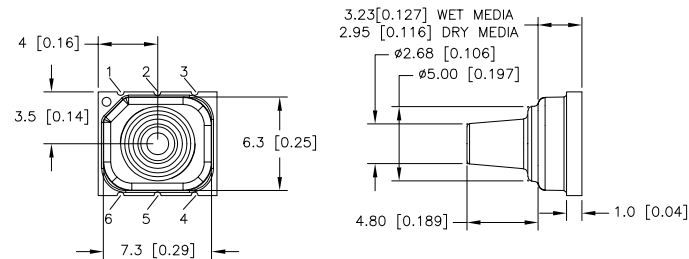
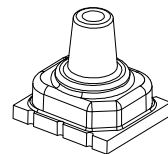

[DIMENSIONS] ARE IN INCHES

TOLERANCES (UNLESS SPECIFIED)

.XX=.01
.XXX=.005
ANGLES=1/2°

MODEL SAABPCS SERIES

Doc No.: OD-SAABPCS
(Rev.A/ 2023-08-18)
Sh 15 of 15

(DCN XXXXX)

THIRD ANGLE PROJECTION

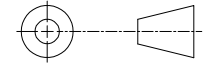

PINOOTS

OUTPUT	PAD 1	PAD 2	PAD 3	PAD 4	PAD 5	PAD 6
I2C	GND	Vsupply	INT	NC	SDA	SCL
SPI	GND	Vsupply	SS	NC	MISO	SCLK
ANALOG	GND	NC	Vout	NC	NC	Vsupply

RECOMMENDED FILTER CAP

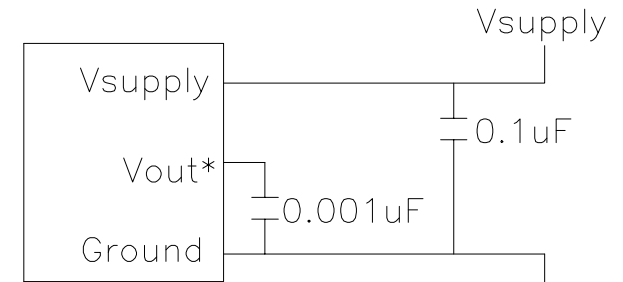

*Analog output version only

RECOMMENDED PCB LAYOUTS

DIP

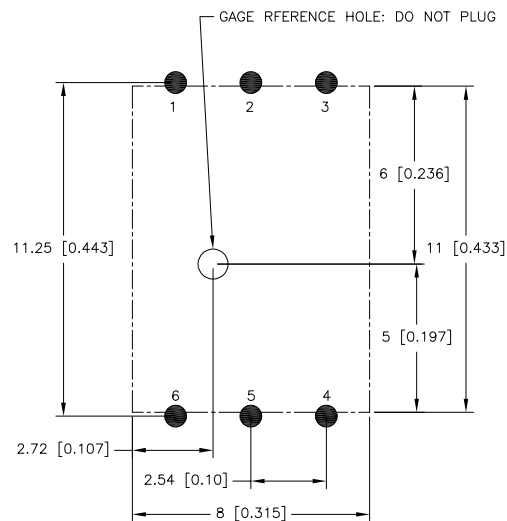

SMT

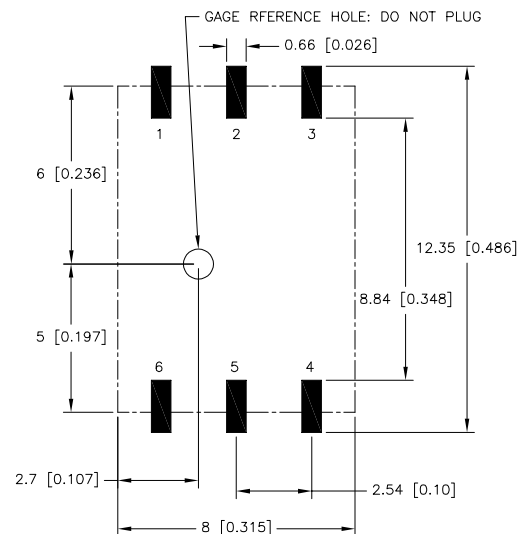

Leadless SMT

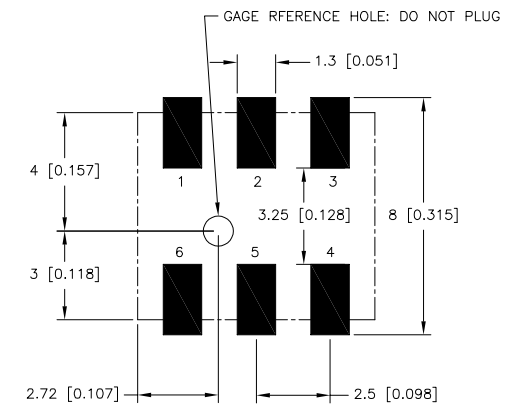

[DIMENSIONS] ARE IN INCHES

TOLERANCES (UNLESS SPECIFIED)

.XX=.01
.XXX=.005
ANGLES=1/2°